

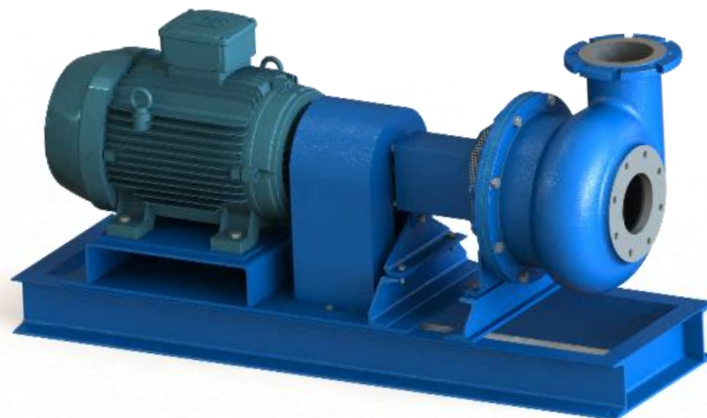

ASSEMBLY AND MAINTENANCE **INSTRUCTIONS**

Type F pump - HT and HG



Contents

INSTRUCTIONS FOR INTERMEDIATE STORAGE :.....	3
INSTRUCTIONS FOR LONG STORAGE :	3
LIFTING INSTRUCTIONS	4
ASSEMBLY INSTRUCTIONS - INSTALLATION	5
COMMISSIONING INSTRUCTIONS & SETTINGS	7
LUBRICATION INSTRUCTIONS	8
HYGIENE / SAFETY INSTRUCTIONS	9
INCIDENTS AND MAIN CAUSES	9
MAINTENANCE PREVENTION	10
SEALING SYSTEM	10
MAINTENANCE INSTRUCTIONS FOR ENGINES.....	11
WARRANTY CONDITIONS	18
EQUIPMENT SUBJECT TO SELF-CERTIFICATION	19

INSTRUCTIONS FOR INTERMEDIATE STORAGE :

- 1- Storage in a closed, dry room
- 2- Minimum / maximum storage temperature: -25°C / + 50°C
- 3- Maximum storage life in standard packaging:
 - For stainless steel pumps: 2 years
 - For pumps made of materials subject to oxidation (cast iron - steel): 6 months

In the event of prolonged storage under different conditions, appropriate protection and packaging must be used.

INSTRUCTIONS FOR LONG STORAGE :

- 1- Always handle equipment with gloves
- 2- Move products with care, avoiding dropping or causing objects to fall on equipment.
- 3- Equipment must be stored away from atmospheric conditions / humidity / dust / saline environments.
 - Remove the pump(s) from their packaging
 - Remove protections (covers or plugs) on suction / discharge where present
 - Spray the following product inside the pump body and onto the impeller, then turn the impeller by hand for at least 3 turns to distribute and coat all the surfaces correctly

o **TECTYL 477-D** oily corrosion prevention concentrate. Film is oily and transparent. Designed to be diluted with mineral oil or solvent. aliphatic. The diluted version protects ferrous and non-ferrous industrial parts.

Properties

Flash point ; COC 157 °C
 Density @ 60°F 0.94 kg/ltr
 Viscosity @ 40°C 100 mm²/s (cst)

TECTYL 477-D reduced 1:9 with mineral oil (22 mm²/s (cst) @ 40°C). ____

Recommended Film thickness 10 microns

Theoretical average coverage 99 m²/l

Accelerated Corrosion Tests: @ Avg. Recommended DFT

Humidity; 100 % RH; @ 40°C; DIN 50 017-KK 50+ days Surface preparation :

The maximum performance of TECTYL 477 - D can only be achieved when surfaces The metal surfaces to be protected are clean, dry and free from rust, oil and scale. It is recommended that the temperature of the metal substrate be between 10 and 35°C at the time of application.

Application of the product.

Ensure uniform consistency before use.

One part of TECTYL 477 -D mixed in 9 parts of mineral oil provides protection to Within 3 - 6 months.

For more protection, one part of TECTYL 477 - D should be mixed with 3 - 4 parts of mineral oil.

Removal :

TECTYL 477 - D can be removed if necessary with mineral spirits or any solvent. or degrease with steam .

Storage :

is recommended before use.

Please note:

For TECTYL 477 - D adequate ventilation is required to prevent the formation of liquids fuel. THE partially cured FILM must not be exposed to sources of ignition.

LIFTING INSTRUCTIONS

Use of textile slings for lifting pump units

Motor-driven pump unit with
frame size >180

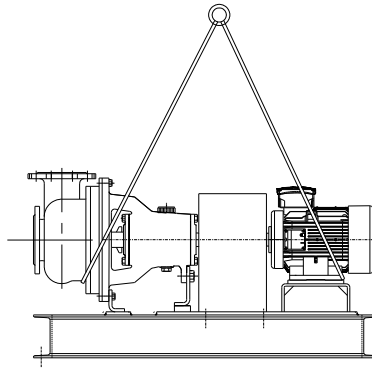

Pump unit with motor frame
size ≥ 180

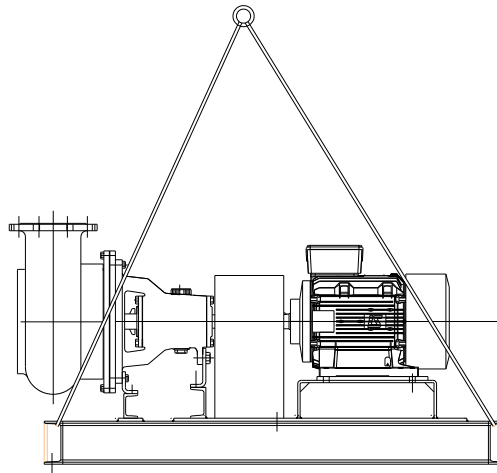

ASSEMBLY INSTRUCTIONS - INSTALLATION

Installation / Set-up

Safety instructions

	⚠ DANGER
	<p>Installation non conforme en zones à risque d'explosion Risque d'explosion ! Endommagement du groupe motopompe !</p> <ul style="list-style-type: none"> ▷ Respecter les prescriptions concernant la protection contre l'explosion en vigueur sur le lieu d'installation. ▷ Respecter les informations dans la fiche de spécifications et sur les plaques signalétiques de la pompe et du moteur.

Check before installing the pump

Installation on an unconsolidated, non-load-bearing surface

- ▷ Ensure that the concrete has sufficient compressive strength. The concrete must comply with class C12/15, exposure class XC1 in accordance with EN 206-1.
- ▷ The installation surface must be horizontal and level, and the concrete must be fully set.
- ▷ Please observe the weights indicated.

The pump unit must be installed in a horizontal position.

Installing the pump

- ✓ The foundation has sufficient strength and the required quality.
- ✓ Place the pump unit on the foundation and use a spirit level to align it with the shaft and flange.
 discharge - Permitted deviation: 0.2mm/m
- ✓ Seal the anchor bolts with concrete or suitable chemical resin.

Pipe connections

- ✓ The pump must not be used as a support point for piping - stress-free connection
- ✓ Compensate for thermal expansion of piping by suitable means
- ✓ Upstream of the suction flange, a straight length equal to at least 2 times the \varnothing of the pipe must be provided.
 to avoid excessive turbulence at the pump inlet
- ✓ The nominal diameters of the inlet and outlet pipes are at least equal to the connection diameters on the pump body
- ✓ In the case of electrical welding work, absolutely avoid connecting the earth of the welding equipment on the pump and avoid back currents in the bearings.

Aligning the pump and motor

Once the pump unit has been installed and the pipes connected, check that they are correctly aligned. the coupling and, if necessary, realign the assembly

Maximum permissible coupling misalignment

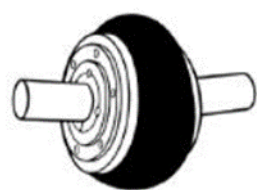

Désalignement angulaire
maxi 4°

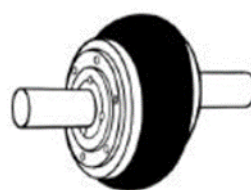

Désalignement radial
maxi 3 mm

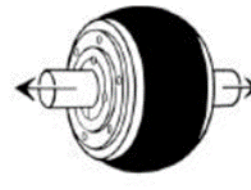

Déplacement axial
maxi 8 mm

WARNING: During operation, the coupling guard, which was removed during the must be in position and fixed to the chassis.

Electrical connection

- ✓ The electrical connection must be carried out by a qualified and authorised electrician.
- ✓ Comply with the requirements of standard IEC 60364
- ✓ Compare the mains voltage with the information on the motor nameplate and choose the right coupling
- ✓ Connect equipotential bonding to earth
- ✓ In accordance with IEC 60034-8, the direction of rotation of three-phase motors is always clockwise. (seen on the motor shaft end). The direction of rotation of the pump is indicated by the arrow on the pump.

CAUTION: Never check the direction of rotation of the pump when running dry → DESTRUCTION of the mechanical seal

Start-up / production

Refer to the start-up instructions following CC DGT 0 NT 230 609 A

INSTRUCTIONS FOR COMMISSIONING & SETTINGS

Pre-start checks

- 1- Only qualified personnel should carry out this work.
- 2- Electrical connections must be made in accordance with good practice and in compliance with the standards and regulations in force at the installation site.
- 3- The pump must be correctly supplied with liquid to prevent the mechanical seal from being destroyed. In all cases, we recommend connecting the mechanical seal watering system to ensure that the seal is lubricated at all times, even when operating without pumping liquid.

Supply pressure= 0.2 bar higher than pump discharge pressure - Flow rate 30 l/h in clear water

- 4- Check that all the pipes are connected and the joints are watertight.
- 5- Check the direction of rotation of the motor (arrow indicating the direction of rotation on the motor cover), by pressing the contactor. In addition, a pulse to check the direction of rotation of the motor will ensure that the friction faces of the mechanical seal are not stuck.

Note: A vortex pump operating in reverse will deliver but may consume 50% more power. There is therefore an overload and a risk of motor damage.

- 6- Check that the level of oil lubricating the bearings is correct.

THE PUMP IS READY TO START

- 1- All valves upstream and downstream of the pump are open
- 2- Putting the engine into service
- 3- Once the engine is at rated speed, check:
 - Correct discharge pressure
 - No vibrations and smooth pump operation
- The mechanical seal may leak slightly on initial start-up. If this leakage does not disappear after a few minutes of operation, stop the pump, remove the friction faces and check their condition.

- 1- All valves upstream and downstream of the pump are open
- 2- Putting the engine into service
- 3- Once the engine is at rated speed, check:
 - Correct discharge pressure
 - No vibrations and smooth pump operation
- The mechanical seal may leak slightly on initial start-up. If this leakage does not disappear after a few minutes of operation, stop the pump, remove the friction faces and check their condition.

Switching off

Before taking out of service, close the valve on the discharge side to prevent suspended matter in the discharge pipe from returning to the pump and clogging the pipes or blocking the impeller when the pump is restarted.

LUBRICATION INSTRUCTIONS

Maximum oil volume = 0.9 litres

CAUTION: The bearings are lubricated by splashing and not by immersion. Check the maximum level against the mark on the dipstick incorporated in the cap.

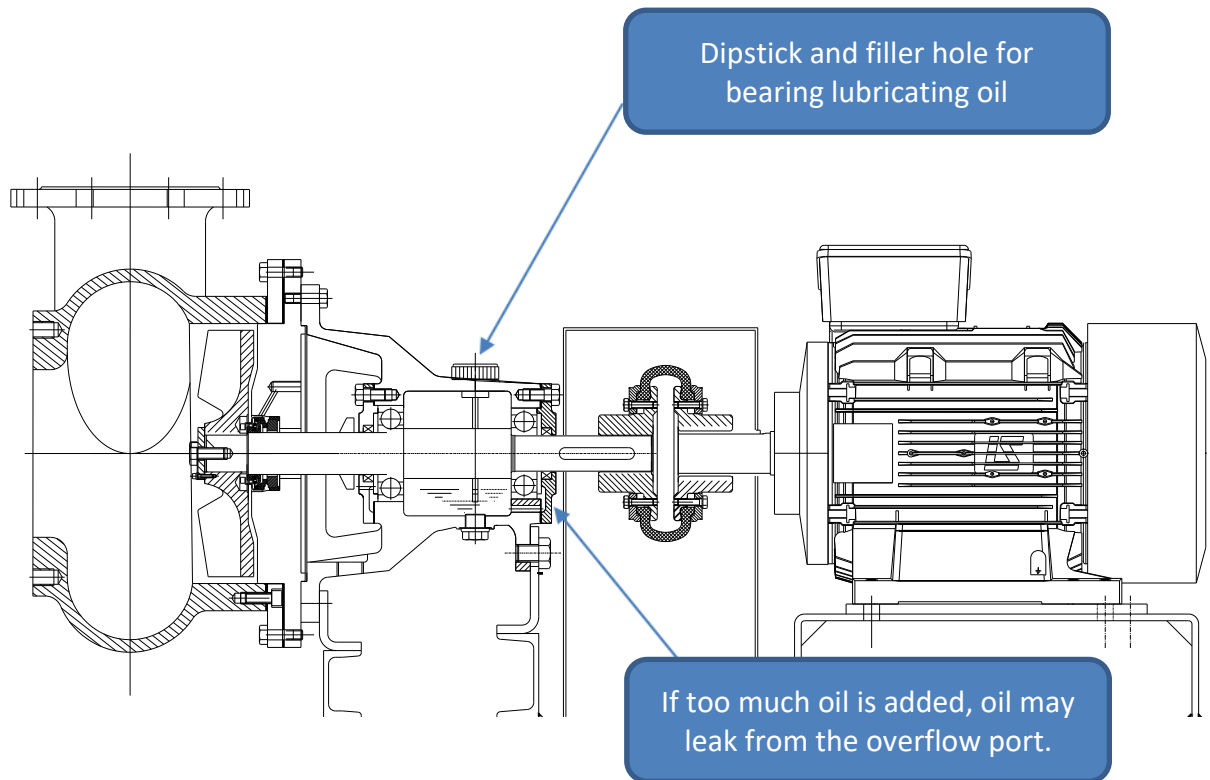

HYGIENE / SAFETY INSTRUCTIONS

Elements concerned:

- Engine
- Coupling

Weekly checks:

- Fixing the motor fan cover
- coupling guard plate fixing

Cleaning:

- Authorised product: compressed air
- Prohibited products: all liquids

INCIDENTS AND MAIN CAUSES

CORRECTIVE MAINTENANCE AND TROUBLESHOOTING

La pompe tourne mais ne refoule pas :	<ul style="list-style-type: none"> -L'impulseur s'est démonté. -Un bouchon obstrue le circuit. -La HMT est supérieure à celle annoncée.
Le moteur disjoncte:	<ul style="list-style-type: none"> -Un corps étranger bloque la turbine. -La HTM est inférieure à celle annoncée. -Le moteur tourne à l'envers -La vitesse de rotation du moteur n'est pas bonne. -La densité du produit est supérieure à celle prévue initialement
La pompe vibre anormalement :	<ul style="list-style-type: none"> -L'impulseur est déséquilibré. -La tuyauterie crée des contraintes sur la pompe. -La HTM est inférieure à celle annoncée.
La pompe fait un bruit anormal:	<ul style="list-style-type: none"> -Le ventilateur moteur frotte sur le capot. -Un roulement est déterioré -L'impulseur frotte dans le corps de la pompe.
La pompe ne donne pas les caractéristiques prévues:	<ul style="list-style-type: none"> -La HMT est supérieure à celle prévue initialement -La viscosité du produit est supérieure à celle annoncée. -Un bouchage s'est produit dans le circuit de refoulement. -La vitesse de rotation du moteur n'est pas bonne. -Le diamètre de l'impulseur ou sa forme n'est pas conforme.

MAINTENANCE PREVENTION

Pump maintenance is limited to checking:

- Check for mechanical seal leakage (shaft seal)
- Checking and topping up the oil level in the bearing box

The frequency with which the condition of the Impeller and the Body is checked varies according to the nature of the products conveyed.

Non-abrasive liquids: half-yearly

Abrasive liquids: quarterly

NOTE: As soon as the pump characteristics decrease, the condition of the impeller should be checked

SEALING SYSTEM

The pump shaft is sealed either by a stuffing box or by mechanical seals.

- Cable gland with graphite braid (HT pump) :

CAUTION: The cable gland must be lubricated with clean, cold water.

This lubrication is used :

- To prevent solid particles suspended in the pumped liquid from entering the stuffing box, which would lead to rapid wear of the pump shaft sleeve.
- Cool the cable gland.

The water pressure must be at least 1 bar higher than the discharge pressure. Watering must be maintained even when the pump is switched off.

- Mechanical seals (HG pump):

Mechanical seals can be fitted on request.

MAINTENANCE INSTRUCTIONS FOR ENGINES

Use and assembly

The motors must be used in accordance with their degree of protection defined in DIN VDE 0530 paragraph 5/en 60034 paragraph 5 and in accordance with their form of construction also defined in DIN IEC 34 paragraph 7.

The suction and discharge openings and the gaps between the cooling ribs must be kept clean to avoid any obstruction.

The cooling air must be drawn in and cooled without discomfort and must not be immediately sucked back in. The distance between the air intake and the nearest wall must be at least equal to the frame size of the motor and coupled to the driven machine.

The driven machine and the mass of the motor have a strong influence on the resonant frequency.

Condensation drain holes

Particular care must be taken to ensure that any condensation drainage holes are located in the lowest part of the motor. They must be kept clean. For motors with IP55 protection, where the condensation drainage holes are blocked, it is necessary to open them at regular intervals.

Transmission components

Pulleys (HT-PC or HG-PC series pumps), sprocket couplings, etc. must be balanced without keys, on a smooth mandrel with a free groove. Before fitting the transmission system, clean the motor shaft with a solvent (e.g. alcohol) to remove the anti-corrosion coating, and grease it.

Use appropriate tools for assembly and disassembly.

Under no circumstances should a hammer be used for assembly, as this will damage the bearings.

Choice of coupling

Only use torsionally flexible couplings in the longitudinal direction which can compensate for eccentricity and angular deviations.

Rigid couplings cannot be used except in exceptional cases,

What you need to know:

- 1) If the bending stress on the shaft is not significant and is within the accepted limits
- 2) If the longitudinal expansion of the motor shaft is not hindered.
- 3) If the shaft centring tolerance, at operating temperature, remains within the limits of the bearing clearance

When using transmission elements that generate axial or radial forces on the motor shaft (e.g. pulleys, pinions, etc.), the diagrams of permissible loads must be requested and taken into account.

Alignment

For a direct coupling, the eccentricity and angular deviation of the shafts must be checked using a dial gauge and a screw-fixed control arm.

The deviation values shown below must not be exceeded:

Eccentricity (radial measurement) 0.03 mm for 2-pole motors, 0.05 mm for 4-pole motors and above.

(the tester indicates double the difference).

Angular deviation (axial measurement) 0.10 mm. Axial clearance between coupling halves $s = 3$ to 4 mm.

Check that the assembly is aligned at operating temperature.

Comparator position for measuring angular deviation

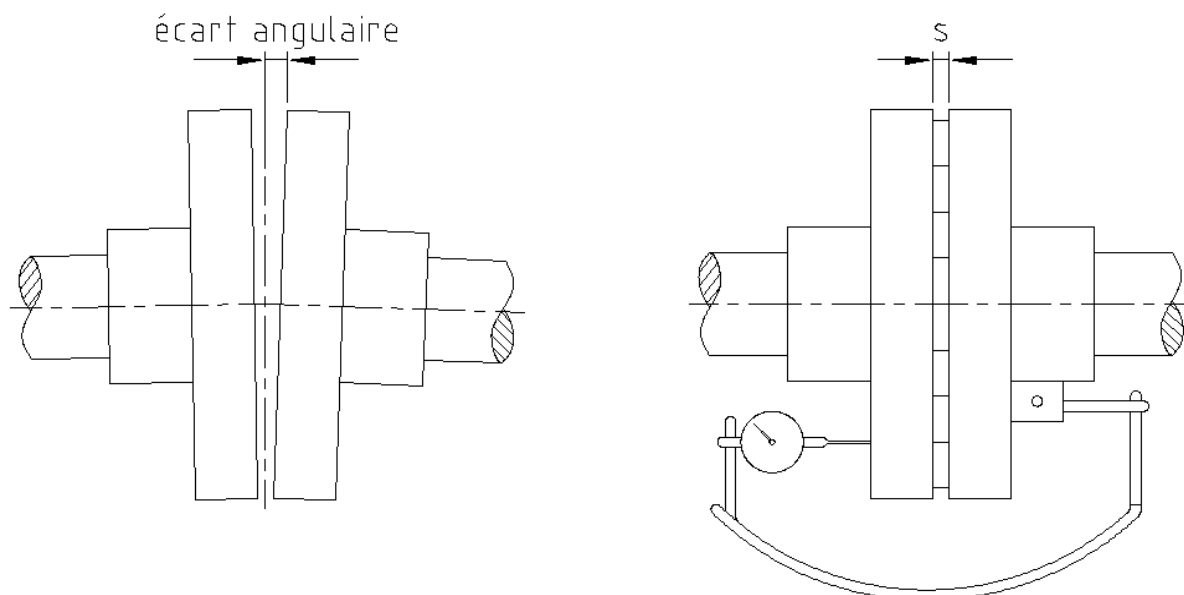

Protection

For protection in the event of short-circuit (blocking), overload or 2-phase operation, the following devices are required:

- 1) Motor protection circuit breaker with trip unit.
- 2) Protection with PTC sensors inserted in the stator windings + trip unit.

Terminal boxes

Can be rotated 90° or 180°. Close unused cable entries.

Motor connection

See page 16 for connection diagrams for three-phase motors with cage or slip-ring rotors, and for single-phase motors. Specific connection diagrams can be found in the terminal box cover or are supplied with the motor.

Connecting the protective wire:

Direction of rotation

For connection of the phases in the order L1, L2, L3 to the motor terminals U1, V1, W1, The direction of rotation is to the right, looking at the shaft extension, or up and to the left, if the terminal box is on the left-hand side.

(For motors with 2 shaft ends, observe the shaft end on the opposite side of the fan).

Reversing the direction of rotation:

Reverse 2 supply wires. All motors - with a few exceptions - are suitable for both directions of rotation.

For motors with only one direction of rotation (with a fan with a defined direction of rotation), the direction of rotation is indicated by an arrow and the additional indication "nur" (only). The order in which the phases L1, L2, L3 must be connected to the motor terminals U1, V1, W1 is also indicated (e.g. for a right-hand position of the terminal box: U1, V1, W1 for right-hand rotation or V1, U1, W1 for left-hand rotation).

Engine bearing maintenance

Permanently lubricated bearings.

Maintenance-free operating life under normal operating conditions: For 2-pole motors: approx. 10,000 hours, For motors with more poles: approx. 20,000 hours.

Maximum life: 4 years. The bearings must then be cleaned. Half-fill the cavities between the balls and the sliding surfaces with grease, as well as the grease boxes. Lubricate the shaft passage of the housings and flanges.

Sealed bearings greased for life (2RS and 2Z) cannot be cleaned or greased and must be replaced.

Bearing fitted with greasing device and grease dispenser

Lubrication intervals and quantities of grease required are indicated on the motor nameplate.

After 12 lubrications, the bearings and casings should be cleaned (with petrol or benzene).

Grease must then be introduced through the grease nipple, turning the rotor slowly until the space between the balls and the sliding surfaces is filled with grease, with the outer housing of the bearing open and the inner housing screwed down.

Lubricant

Lithium grease K 3 N to DIN 51825 (water behaviour to DIN 51807 paragraph 1, rating level 0 or 1). Only use an equivalent grease for lubrication (e.g. Esso Unirex N3, Shell-Alvania R3, Esso-Beacon 3, etc.).

Maintenance of stored engines

Store motors in a dry, clean place, away from shocks or vibrations. For motors fitted with cylindrical roller bearings, leave the transport locks in the locked position.

If the motors have been exposed to moisture for a long time during storage, the insulation resistance of the windings in relation to the frame should be measured using a hand-cranked magneto (maximum DC voltage 500 V). If the resistance is less than 30 M Ω for a winding temperature of 25°C or less than 1 M Ω for a temperature of 75°C, the motor must be dried (the winding temperature must not exceed 80°C).

For enclosed motors, remove one endshield to allow air to circulate. If the windings are dried by a low-voltage connection, ask the motor manufacturer for instructions.

After drying out or after more than 4 years' storage, the bearings should be overhauled (see "Bearing maintenance" section). For motors fitted with a grease nipple, greasing with a double quantity of grease is sufficient.

MOTORS FOR OPERATION IN EXPLOSIVE ATMOSPHERES

Use

For installation and operation, observe the regulations in accordance with DIN VDE 0165. If there is any doubt about the degree and extent of the explosion risk, the competent authority responsible for the site will decide.

Motor protection

They must be protected against any impermissible overheating due to overloading by a motor protection circuit breaker corresponding to the requirements of VDE 0660, or any other equivalent system capable of protecting each of the poles. The breaking capacity of the motor circuit breaker must be greater than the starting current I_a of the motor (test current in accordance with DIN VDE 0660 for cut-in and cut-out tests).

Regulations for EEx e engines

Timed current releases and relays should be set according to the rated motor current. In addition, they must be chosen so that the motor is thermally protected in the event of short-circuit operation, i.e. locked rotor. This is considered to be achieved when the tripping time given by the tripping curve for the ratio I/I_{an} is not greater than the heating time t_E (indicated on the motor nameplate) to reach the temperature corresponding to the temperature class (initial temperature: 20°C).

Motors with switchable poles, time-delayed current triggers or relays that can be interlocked must be provided for all speeds.

The motors may only be used for continuous duty without frequent start-ups and where start-ups do not cause significant overheating.

Connection

The cable glands provided for balancing the tensile or torsional forces must be used as intended. After loosening the screws or nuts, insert the supply wires between the lower parts and the pressure piece of the terminals.

The stripped ends of the wires must fill the total length of the terminals, but must not exceed it. Check that the wires are in the correct position, then tighten the screws or nuts.

Connect the protective wire to the neutral terminal inside the terminal box or, if there is a separate earth, connect it to the earth terminal.

Repairs

Any modifications or repairs to explosion-protected motors may only be carried out by authorised workshops, or workshops recognised as experts by the competent local authority. Overhauls that have no effect on the explosion-proof devices of Eex e engines may be carried out without the assistance of an authorised body. These repairs include maintenance work and mechanical repairs, e.g. changing the terminals, changing the bearings, repairing the fan and fan cover, welding broken lugs and changing the sealing washers. Only original spare parts may be used for the replacement of important parts.

SLIP-RING ROTOR MOTOR

Installation

To commission motors fitted with brushes in series, the following conditions must be met: The atmosphere must not be aggressive; for IP23 motors, there must be no significant presence of dust. The air humidity must be sufficient (approximately 8 to 25 g/m³). Caution: hygroscopic dust absorbs humidity from the ambient air and reduces its level accordingly! The actual output must be at least 70% to 100% of the rated output at rated speed. Failure to comply with any of these conditions will result in premature wear of the brushes and the formation of scratches on the rings.

Collector enclosure opening

For inspection or maintenance purposes, the manifold housing must only be opened when the machine is stopped. It is important to reseal this part after carrying out the work. If the motor cannot be stopped, eliminate the blast effect of the external fan by covering its cover (for motors with a ventilated casing). As cooling is reduced, do not cover the bonnet for more than 10 minutes at most.

Checking the brushes

The inspection intervals are as follows:

After 10 hours of service, check for excessive wear. After 100 hours of service, check for wear (normal maximum 1.2 mm per 100 hours of service). The rings should be dark in colour across the width of the brushes.

(patina). For constant ambient conditions and normal brush wear, repeat the check after 500 hours and then every 1000 hours of service.

Replacing brushes

The remaining length of a brush should not be less than approximately $\frac{1}{4}$ of the original length. Grind the new brushes with emery cloth so that the entire surface carries.

Cleaning

Remove all traces of brush dust from the commutator part every 1000 hours of service and before a new set of brushes is fitted. Vacuum the dust from the brushes (avoid it being blown into the winding). Any remaining traces of dust should be removed with a cloth.

If the surface of the rings is damaged by small pittings or heavily oxidised, it must be turned (maximum out-of-round 0.05 mm).

If the sliding surface of the bushes extends beyond the insulation by only about 0.5 mm, this operation is no longer possible.

Connection diagrams for three-phase squirrel-cage motors

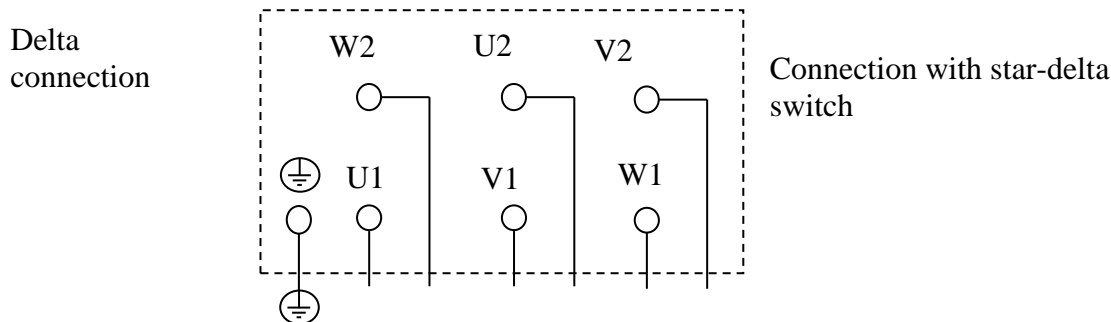

Connection diagrams for pole-changing three-phase motors

2-speed motor with separate windings:

In the type designation, the lowest number of poles = high speed is mentioned first. (e.g. AM 280... 4/8)

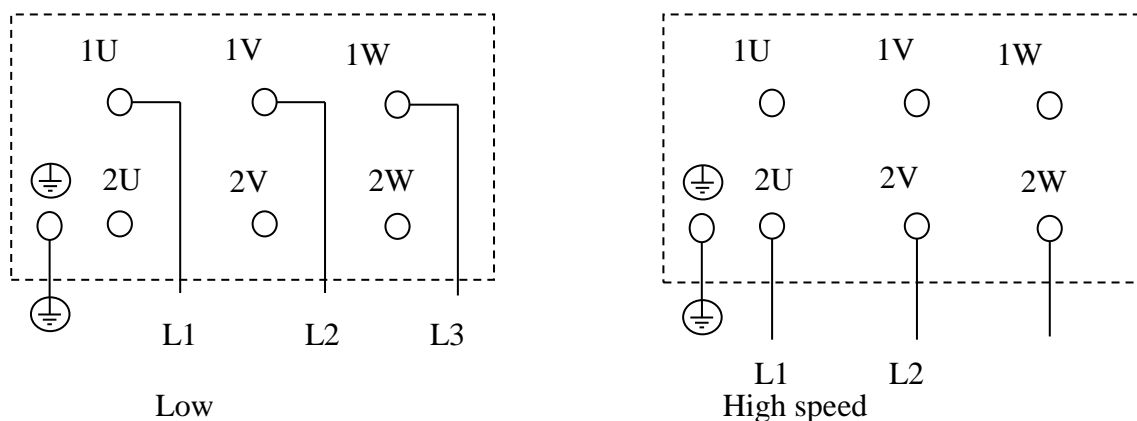

WARRANTY CONDITIONS

Our pumps are guaranteed parts and labour recognised as defective by our after-sales service (equipment returned to our workshops).

Except:

- Case of abnormal operation.
- Service other than that provided for in the order.
- Lack of control and maintenance.
- Wear part.

Wear parts: Body

- Impeller
- Mechanical braid or packing



**DECLARATION OF CONFORMITY WITH
MACHINERY DIRECTIVE**
(Directive 98/37/EC of 22 June 1998) and the regulations
implementing it

EQUIPMENT SUBJECT TO SELF-CERTIFICATION

The manufacturer:



14, Avenue des vieux moulins
Z.I de Vovray
74000 ANNECY
Tel. 04.50.10.10.40

Declares that the machine designated below

HORIZONTAL VORTEX PUMP

Model F HT or HG

- complies with the provisions of the Machinery Directive (Directive 2006/42/EC) and the national legislation transposing it
- complies with the following Harmonised European Standards:

CEN / TC 197 / SC1 N 36 E (pr EN 809)

Transposed into French law by law N° 91 1414 (decrees N°92-765, 92-766 and 92-767 of 29.07.1992).

Signed in
ANNECY,

03/01/2023

Name of signatory: S.CHENAL

Signature :

