

ESP GROUPE



EVA SEIM POMPES GROUPE

ASSEMBLY AND MAINTENANCE
INSTRUCTIONS

Pump Type VM-SCA / VMT-SCA / VMS-SCA
(all these types exist in:
SCA normal version,
SCA AL reduced version
SCA AS dry version
and the SCA SL heavy version)



CONTENTS

1. PRODUCT DESCRIPTION – PRINCIPLE OF OPERATION	Page 3
1.1 Construction pump detail	Page 3
1.2 Rating plate	Page 4
1.3 Principle of operation	Page 4
2. INSTRUCTIONS FOR ASSEMBLY AND INSTALLATION	Page 5
2.1 Storage	Page 5
2.2 Handling	Page 5
2.3 Installation	Page 5
2.4 Line connection	Page 5
2.5 Electrical connection	Page 5/6
3. INSTRUCTIONS FOR COMMISSIONING AND ADJUSTMENTS	Page 7
4. MAINTENANCE, SERVICE AND SAFETY	Page 8
4.1 Preventive maintenance and checks	Page 8
4.2 Incidents and main causes	Page 9
4.3 Dismantling the various pump components	Page 10
5. CONDITIONS AND GUARANTEES	Page 11
6. APPENDICES	Page 12
6.1 Type of lubricant	Page 12
6.2 Frequency of lubrication	Page 14
6.3 Quantity of lubricant required	Page 15
6.4 Replacement parts list	Page 16
6.5 EC Certificate of conformity	Page 17

1. PRODUCT DESCRIPTION – PRINCIPLE OF OPERATION

- Vertical centrifuge pump centrifuge with submerged housing with VORTEX wheel.
- Dry operation without risk of deterioration.
- Sludge lifting.

1.1 Pump construction detail

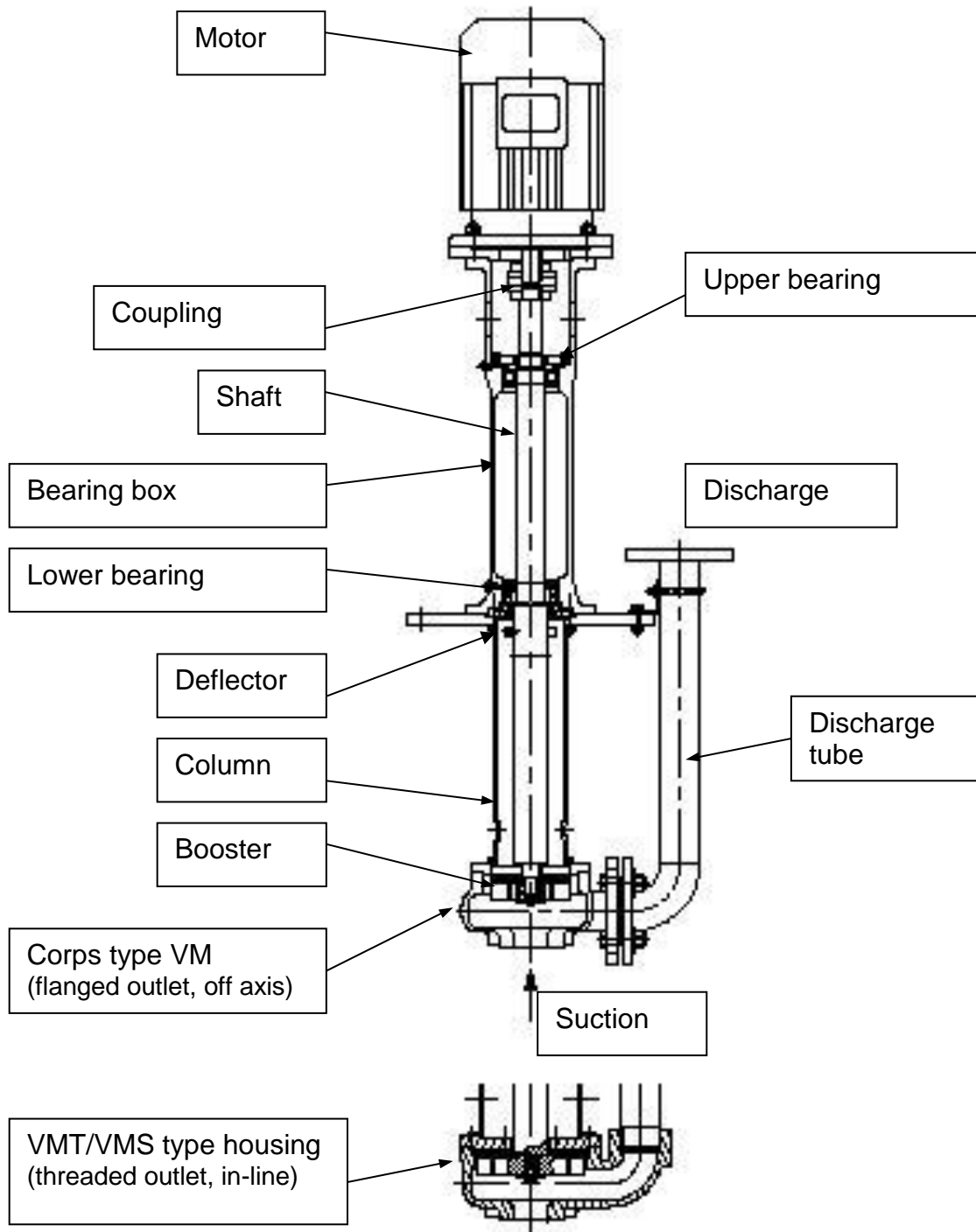

1.2 Rating plate

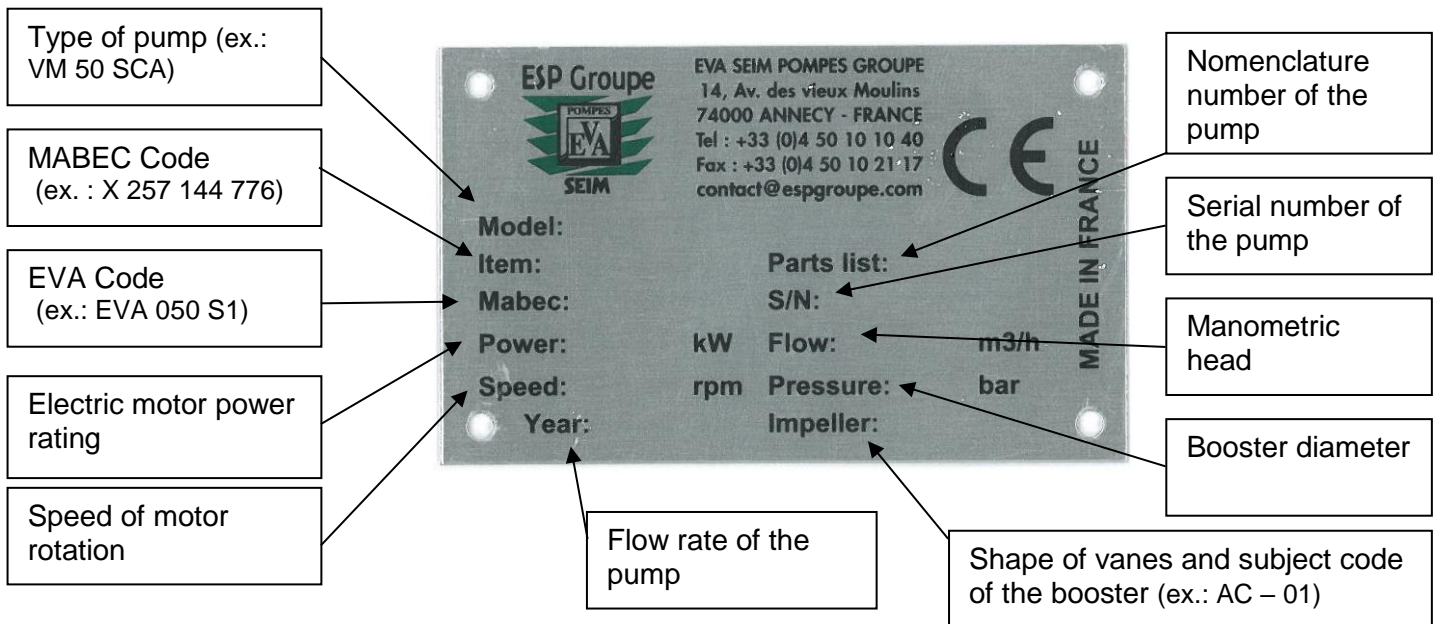

The rating plate specifications must be given for all requests for after-sales-service and/or replacement parts.

1.3 Principle of operation

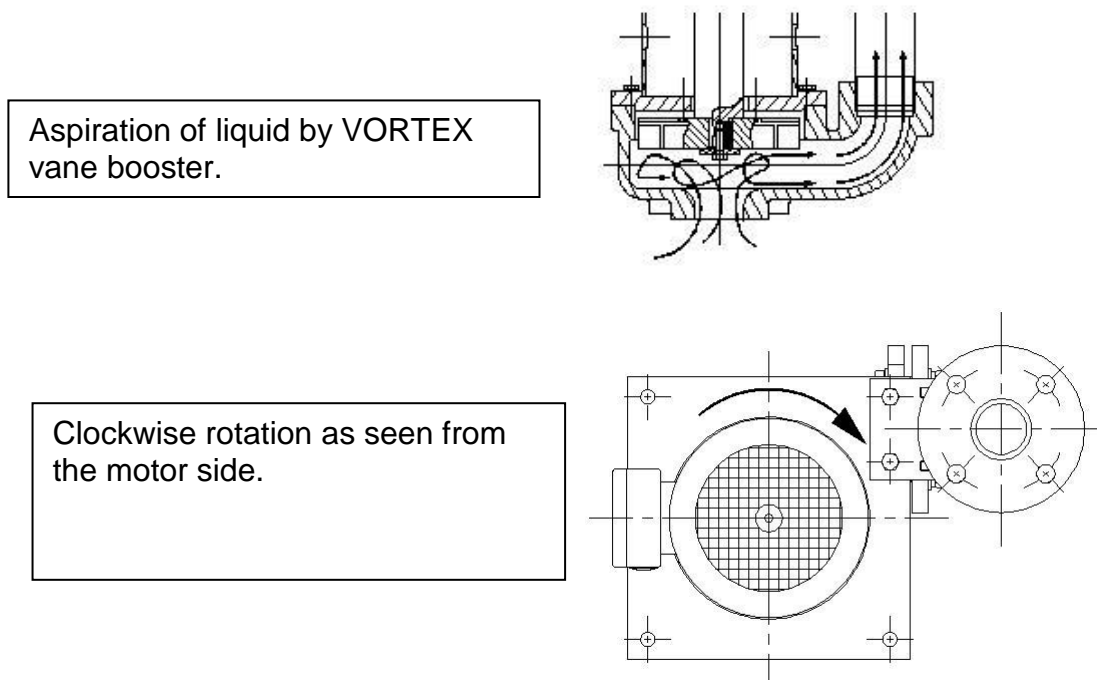

2. INSTRUCTIONS DE MONTAGE ET DE MISE EN PLACE

2.1 Storage

It is preferable to store the pump covered, in its original packaging.

In case of long storage (> 1 year), you must check before start:

- If the lip seals upper and lower of the bearing box are not dry
- If grease inside the bearing box (next to bearings) is not dry

2.2 Manutention

For handling and installation on the trough, sling the pump above the motor.

2.3 Installation

Before installation, make sure that:

- the base plate of the trough is completely level.
- the trough has been cleaned before placement in water.
- **On the «SL» versions, remove the 4 locking screws of the shaft that are placed on the bottom of the column that serve for transport.**

2.4 Connecting the line

- The diameter of the discharge line should not be less than the nominal diameter of the pump. (Especially when pumping large shavings).
- The discharge line should be perfectly maintained independently of the pump.
- **The pump should never withstand the constraints of misalignment or the weight of the discharge line. These cause premature wear and tear of the pump's mechanical components.**
- The suction diameter should not be reduced.

2.5 Electrical connection

- The stuffing boxes provided to balance tractive effort or torsional stress should be used in compliance with regulations. After loosening the screws or nuts, insert the power leads between the lower part and the presser of the terminal posts.
- The stripped ends of the wires should fill the entire length of the terminals however, they should not jut out. Make sure the leads are well in place and then retighten the screws or nuts.
- Connect the guard wire with the neutral terminal found inside the terminal box or in the case of a separate earth, connect the latter to the earth terminal.

- **Connection diagrams for three-phase motors with cage rotors**

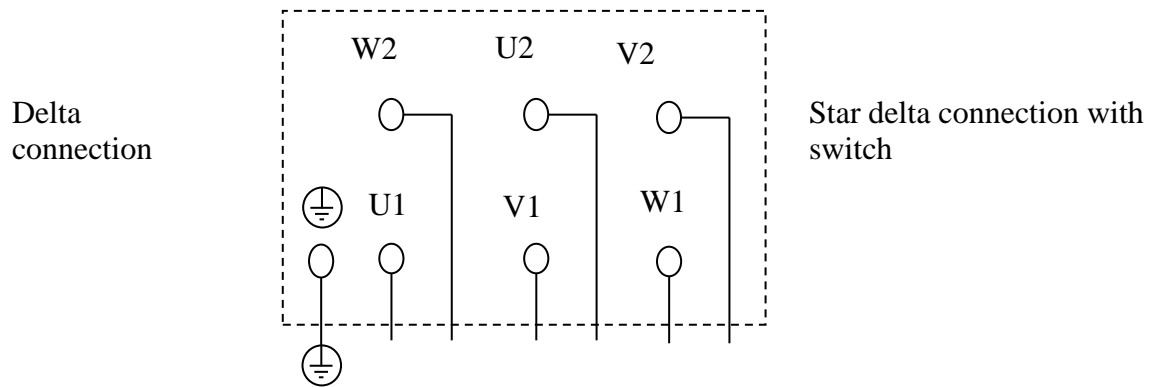

- **Connection diagrams for three-phase motors with switchable poles**

2 speed motor with separate interwindings:

In this type of designation, the fewer the number of poles = the high speed is mentioned first (ex. AM 280 . 4/8)

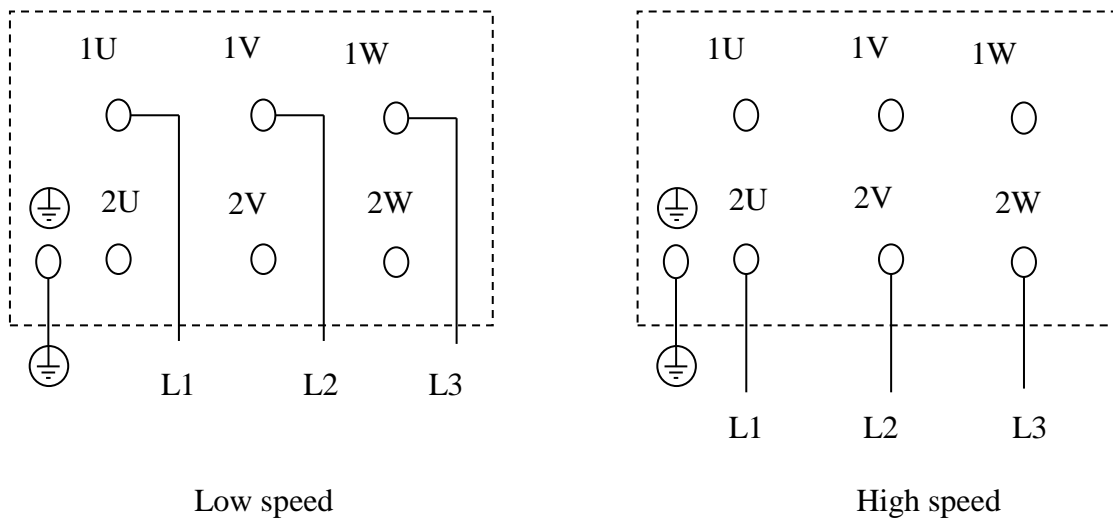

The individual connection diagrams are found in the lid of the terminal box or delivered with the motor.

3. INSTRUCTIONS FOR COMMISSIONING AND ADJUSTMENTS

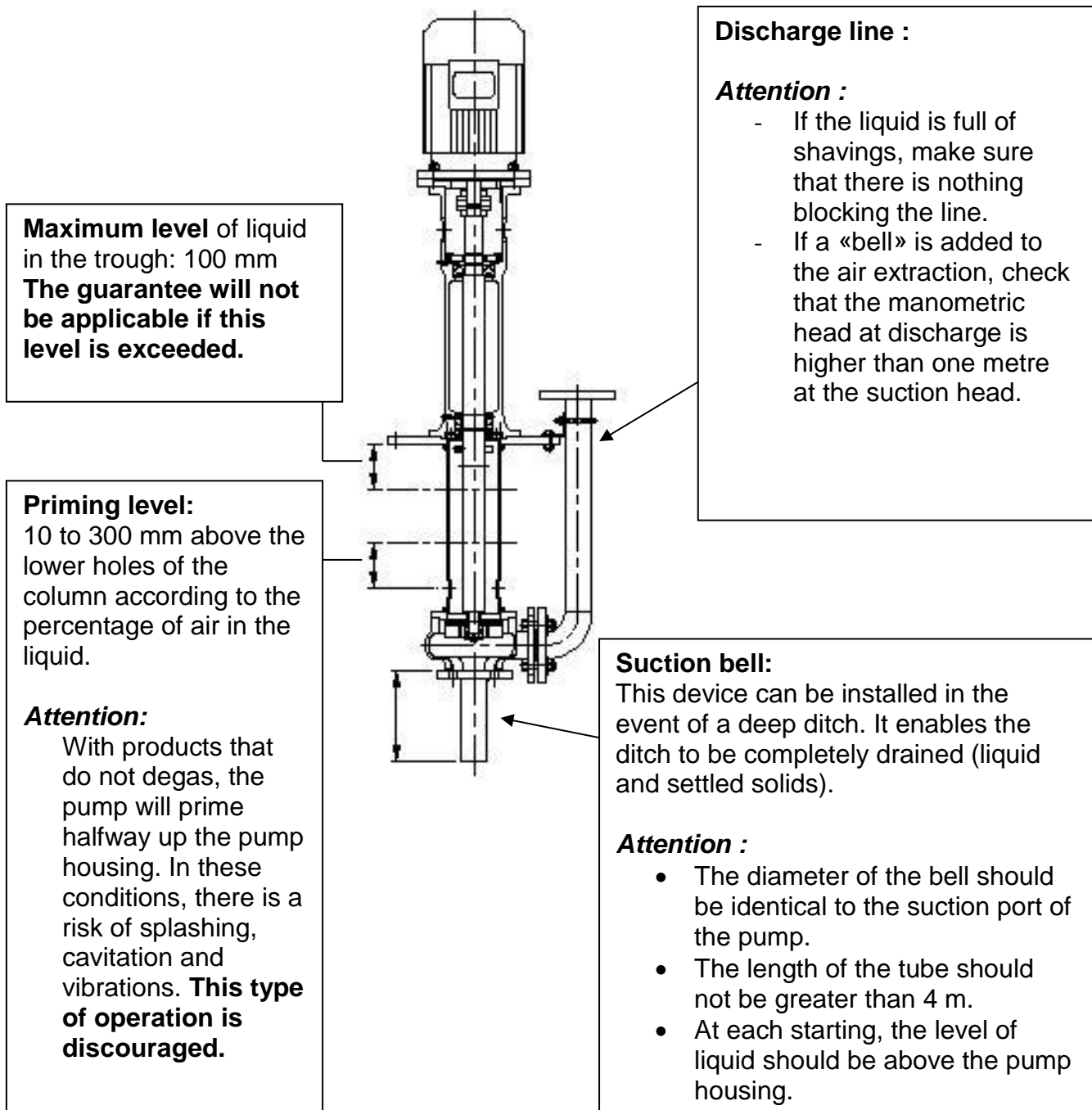

When commissioning, check the direction of the pump's rotation (clockwise when seen from the motor side).

Attention:

A VORTEX pump that turns in reverse discharges about 80% of its rated flow but consumes much more amperage (The lowest amperage corresponds to rotation in the right direction).

4. MAINTENANCE, SERVICING AND SAFETY

Before any intervention, make sure that the pump has been shut down:

- Electrical power cut.
- Hydraulic network disconnected.

Use personal protective equipment and the correct tools.

4.1 Preventive maintenance and checks.

- **Cleaning:**



_Clean the motor regularly with compressed air in order to avoid any obstruction of the cooling flanges.

Never use liquid products.

- **Regular checks (at least montly):**

- Inspect the fan motor cowling supports.
- Inspect the condition of the various electrical and hydraulic connections.
- Inspect abnormal noises, vibrations and any phenomena that could signal the deterioration of a pump component, the motor or a failure of the discharge line support structure.
- Inspect the greasing if applicable.

- **Regular checks and maintenance (at least quarterly):**

- Check the condition of the coupling flector.
- Greasing the bearings (the SCA AL versions are not concerned because the installed bearings are greased for life). For the type of lubricant and the frequency of greasings see the instructions found in the appendices.

- **Checking and replacing the booster:**

Checking and/or replacing the booster require dismantling the motopump assembly. See chapter 4.3, page 10 for the dismantling procedure.

- Half-yearly inspection for non-abrasive liquids. Quarterly inspection for abrasive liquids.
- Immediate inspection if the specifications of the pump diminish.

4.2 Incidents and main causes

CORRECTIVE MAINTENANCE AND TROUBLE-SHOOTING

The motor functions, but not the pump:	<ul style="list-style-type: none"> - The half plates of the coupling are incorrectly joined.
The pump functions but does not discharge:	<ul style="list-style-type: none"> - The booster is no longer on its shaft. - A plug is obstructing the discharge system. - The MTL (manometric total lift) is higher than that announced.
The motor cuts out:	<ul style="list-style-type: none"> - Something is blocking the turbine. - The MTL (manometric total lift) is lower than that announced. - The motor is turning in reverse. - The motor's rotation speed is not good. - The product is denser than expected.
The pump vibrates abnormally:	<ul style="list-style-type: none"> - The coupling is badly blocked. - The discharge line is constraining the pump. - The base plate is not attached to a level support. - The MTL (manometric total lift) is lower than that announced. - The booster is damaged (loss of balancing).
The pump makes a strange noise:	<ul style="list-style-type: none"> - The fan motor is rubbing against the cowling. - A bearing has deteriorated. - The booster rubs in the pump housing.
The pump is not performing as rated:	<ul style="list-style-type: none"> - The MTL (manometric total lift) is higher than initially expected. - The viscosity of the product is different from that announced. - The discharge system is clogged. - The motor rotation speed is not good. - The diameter or shape of the booster does not comply.

4.3 Dismantling the various pump elements

- **Removing the pump from its trough:**
 - Uncouple the discharge line.
 - Unscrew the 4 fastening screws of the column plate.
 - Remove the motopump assembly and put it on an appropriate support.

- **Remove the pump housing:**
 - Remove the 4 fastening screws of the housing.
 - Remove the housing.
- **Remove the booster:**
 - Remove the support screw of the booster and its washer.
 - Remove the booster.

- **Uncoupling the motor – axle box:**
 - Remove the 4 motor fastening screws.
 - Remove the motor with its 1/2 coupling.
- **Uncoupling the axle box – column:**
 - Remove the 4 attaching screws of the axle box.
 - Take out the axle box assembly and the shaft.
- **Uncoupling the shaft – bearing box:**
 - Remove the motor counter flange, or the lantern, depending on the assembly.
 - Remove the deflector mounted on the shaft.
 - Remove the bearing caps, slotted nuts or the lock rings, depending on the assembly.
 - Extract the bearings from the hub extractor.
- **Reassembly:**
 - Carry out the various operations in reverse order.

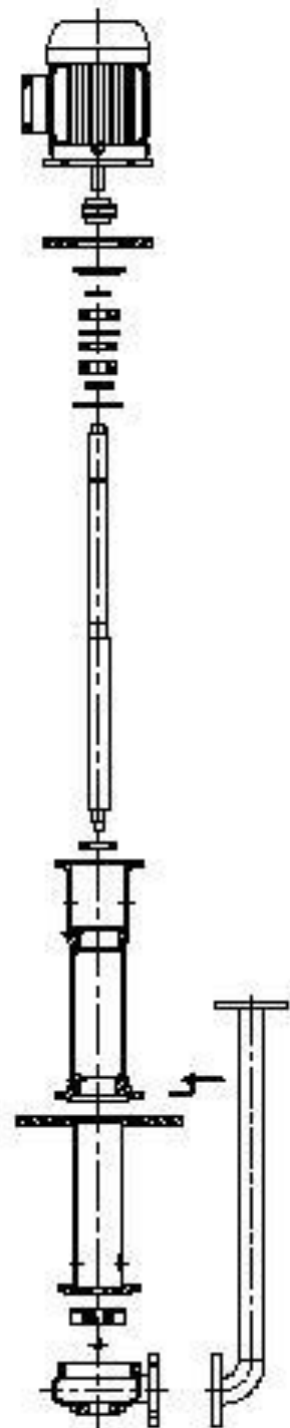

5. CONDITIONS OF GUARANTEES

The pumps are guaranteed for parts and labour if recognized as defective by our after-sales-service (materials returned to our workshops).

Excluded from the guarantee:

- Abnormal running
- Operation other than that provided for when ordered.
- Lack of checks and maintenance.
- Wearing parts

Wearing parts

- Booster
- Upper and lower bearings
- Coupling flector

6. APPENDICES

6.1 Type of lubricant.

SKF offers a choice of six types of grease, covering 90% of the practical applications where grease is recommended as a lubricant. The choice of the correct quality is therefore easier. They are stocked by the entire SKF sales network. These greases are homogenous and stable, as well as in conformity with parts 1 to 3 of DIN 51825 specifications. Their quality is constantly monitored by practical operation, chemical and physical testing. The chart below shows the technical specifications of the SKF range of greases.

SKF lubricating greases							
Properties	Designation of greases						
	LGMT 2	LGMT 3	LGEP 2	LGEM 2	LGEV 2	LGLT 2	LGHT 3
Lithium thickener	Lithium soap	Lithium soap	Lithium soap	Lithium soap	Lithium/calcium soap	Lithium soap	Lithium complex
Oil base	mineral	mineral	mineral	mineral	mineral	mineral	mineral
Working temperature, °C (continuous operation)	-30 to +120	-30 to +120	-30 to +120	-30 to +120	-30 to +120	-30 to +120	-30 to +120
Kinematic viscosity of the oil base mm ² /s to 40°C	91	120	195	510	1020	16	110
Viscosity of the oil base mm ² /s to 100°C	10	12	15	32	58	3,8	13
Consistency (NGLI)	2	3	2	2	2	2	3

SKF LGMT 2

«All-purpose» grease for general and industrial use. Specially adapted to small and medium sized bearings, even in difficult conditions. LGMT 2 has excellent water-repellent properties and offers good protection against corrosion. Typical fields of application: agricultural machinery, automobile wheels, small electric motors, conveyers, etc.

SKF LGMT3

«All-purpose» grease for general industrial applications. With a slightly higher viscosity than LGMT 2, this quality is suitable for medium and large sized bearings, even in difficult conditions. LGMT 3 has excellent water repellent properties and offers remarkable protection against corrosion. Therefore, it is particularly recommended for assemblies where water and humidity could affect the bearings, for example in pumps, agricultural machines, electric motors, truck wheels and fans operating at normal ambient temperature.

SKF LGEP 2

High performance grease for very demanding applications, adapted to medium and large sized bearings, especially spherical roller bearings on wheels. This quality offers excellent resistance to water and good protection against corrosion, even in difficult applications. Typical fields of application: rolling mills, grinding mills, paper machines and pulp preparation.

SKF LGEM 2

Grease with a molybdenum disulphide-based additive for bearings subjected to heavy loads and substantial shocks, particularly with slow rotation or oscillation. It is also applicable to steel/steel plain bearings. LGEM offers excellent resistance to water and remarkable protection against corrosion. Typical fields of application: grinding mills, converters, supporting rollers and equipment for the building industry.

SKF LGEV2

Was specially developed for very heavy loads. They have a thick base oil and contain EP additives as well as molybdenum disulphide and graphite-based safety lubricants. It is very suitable for spherical roller bearings on wheels subjected to heavy loads and slow rotation or oscillation. Typical fields of application: high-pressure roller grinders, Yankee cylinders, drums, supporting rollers, stop rollers, etc.

SKF LGLT 2

Suitable for small bearings with small load where operating temperatures are not so high and highly consistent rotation is required. This quality can be used in high-speed low temperature applications, for example instruments, control systems, machine tool spindles and textile machinery.

SKF LGHT 3

High temperature grease for bearings up to +150 °C. A periodical, regular lubrication schedule allows temperatures up to +175 °C. Typical fields of application: fans operating above 100 °C, tunnel furnaces and disc brake systems.

6.2 Frequency of lubrication

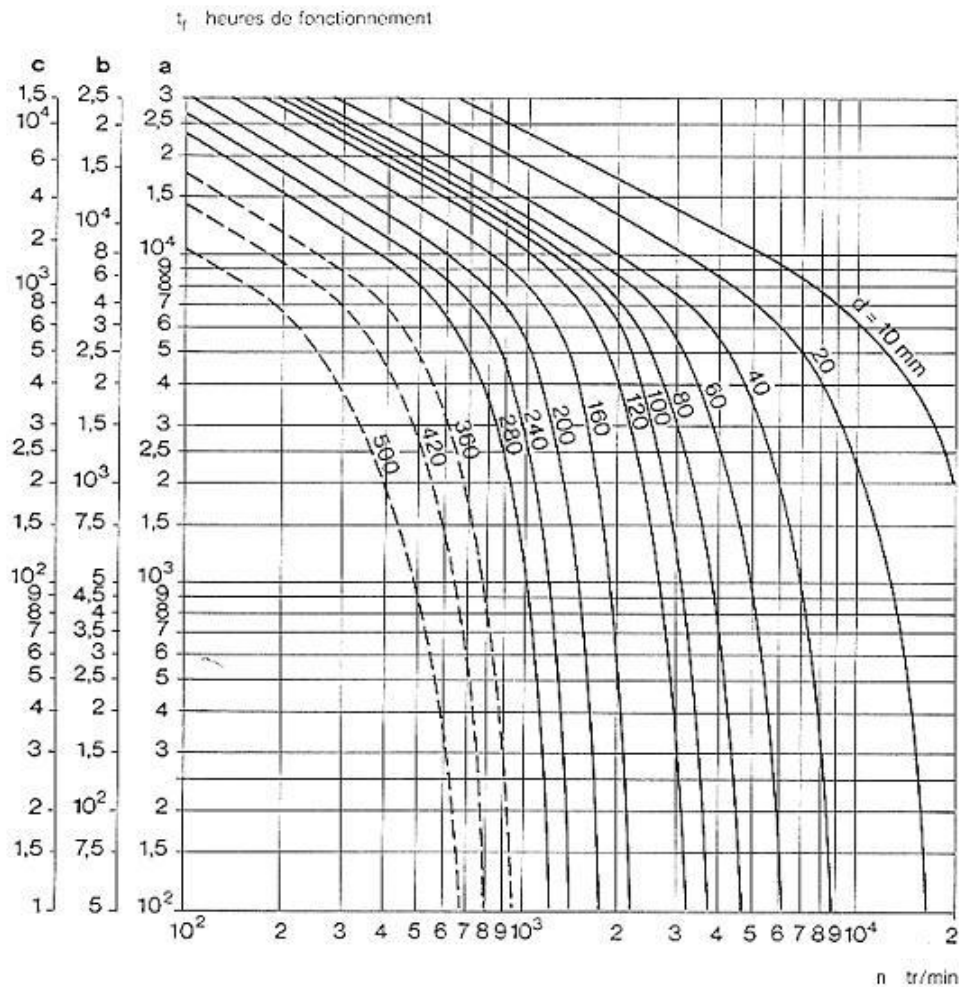

The SKF diagram is based on the use of normal quality grease that is resistant to ageing and gives the time between lubrication in working hours. It is valid for stationary machines, normal loads on bearings and operating temperatures up to +70°C as measured on the bearings external ring. For each increase of 15°C above +70°C, the time between lubrication obtained from the diagram should be divided by two but the upper temperature limit of the grease should not be exceeded. Assemblies where the grease risks being quickly contaminated or else requiring protection against water should receive lubricant touch-ups more frequently than indicated by the diagram.

6.3 Quantity of lubricant required.

Without special instructions, the quantity of grease to be used should be obtained by the following equation:

$$G = 0.005 D B$$

G: quantity of grease in grams

D: outside diameter of the bearing in mm

B: width of the bearing in mm

6.4 Spare parts list

The rating plate specifications must be given for all requests for replacement parts.

- Booster
- Housing
- Pump shaft
- Bearings (couvercle, cover joint and lock rings)
- Motor
- Coupling

6.5 CE Certificate of conformity



DECLARATION OF CONFORMITY
WITH THE
DIRECTIVE « MACHINES »
(Directive 98/37/CE of 22 June 1998) and to the
regulations for its transposition

MATERIEL SUBJECT TO AUTO CERTIFICATION

The manufacturer:



14, Avenue des vieux moulins
Z.I de Vovray
74000 ANNECY
Tel. 04.50.10.10.40

Declares that the machine designated below:

VERTICAL PUMP WITH VORTEX EFFECT AND BEARING BOX

Model: VM - SCA / VMT - SCA / VMS – SCA
VM – SCA AL / VMT – SCA AL / VMS – SCA AL
VM – SCA AS / VMT – SCA AS / VMS – SCA AS
VM – SCA SL / VMT – SCA SL / VMS – SCA SL

- Conforms to the provisions of the directive « MACHINES » (Directive 89/392/EEC modified) and to the national laws that transpose it.

Conforms with the following provisions of the European Harmonized Standards:
CEN / TC 197 / SC1 N 36 E (pr EN 809)

Transposed in French by law N° 91 1414 (decrees N° 92-765, 92-766 and 92-767 of 29.07.1992).

Signed at ANNECY,

The 22.02.2024

Name of the signer: B. CRESPI

Signature :

