

**ESP GROUPE**



## **ASSEMBLY AND MAINTENANCE** **INSTRUCTIONS**

**Pump Type VM-SCM / VMT-SCM / VMS-SCM /  
SVD-SCM**



## CONTENTS

1. PRODUCT DESCRIPTION – PRINCIPLE OF OPERATION .....	3
1.1 Pump construction detail .....	3
1.2 Rating plate .....	4
1.3 Principle of operation.....	4
2. INSTRUCTIONS FOR ASSEMBLY AND INSTALLATION .....	5
2.1 Storage .....	5
2.2 Handling.....	5
2.3 Installation.....	5
2.4 Connecting the line .....	5
2.5 Electrical connection.....	5
3. INSTRUCTIONS FOR COMMISSIONING AND ADJUSTMENTS .....	7
4. MAINTENANCE, SERVICING AND SAFETY .....	8
4.1 Preventive maintenance and checks. ....	8
4.2 Incidents and main causes.....	9
4.3 Dismantling the various pump elements.....	10
5. CONDITIONS OF GUARANTEES.....	11
6. APPENDICES.....	12
6.1 Assembly sheet for the RING-BLOCK bushing.....	12
6.2 Spare parts list.....	14
6.3 Certificate of EC conformity .....	15
MATERIAL SUBJECT TO AUTO CERTIFICATION .....	15

## 1. PRODUCT DESCRIPTION – PRINCIPLE OF OPERATION

- Vertical centrifuge pump with submerged housing and VORTEX wheel.
- Dry operation without risk of deterioration.
- Sludge lifting.

### 1.1 Pump construction detail

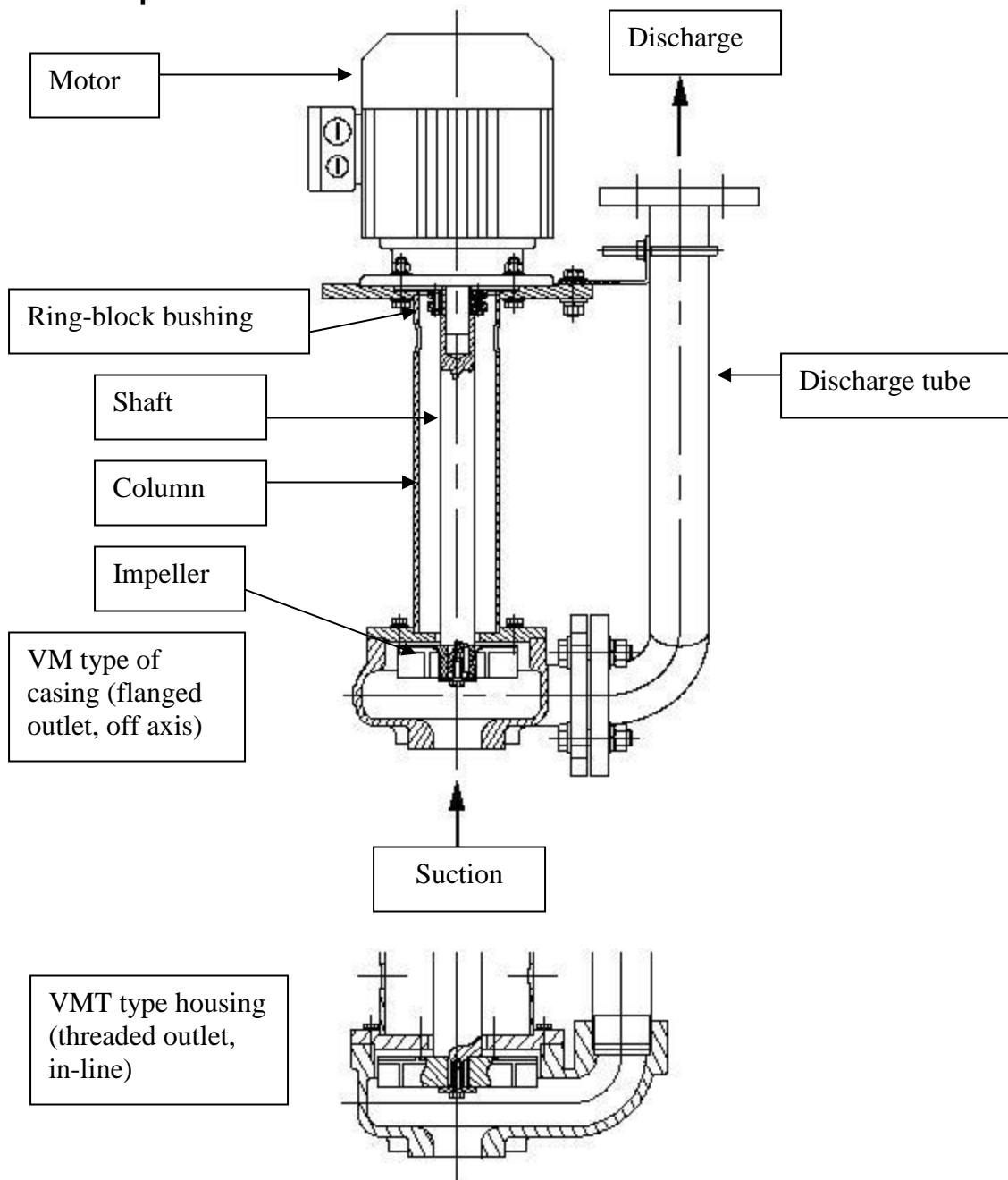

### 1.2 Rating plate

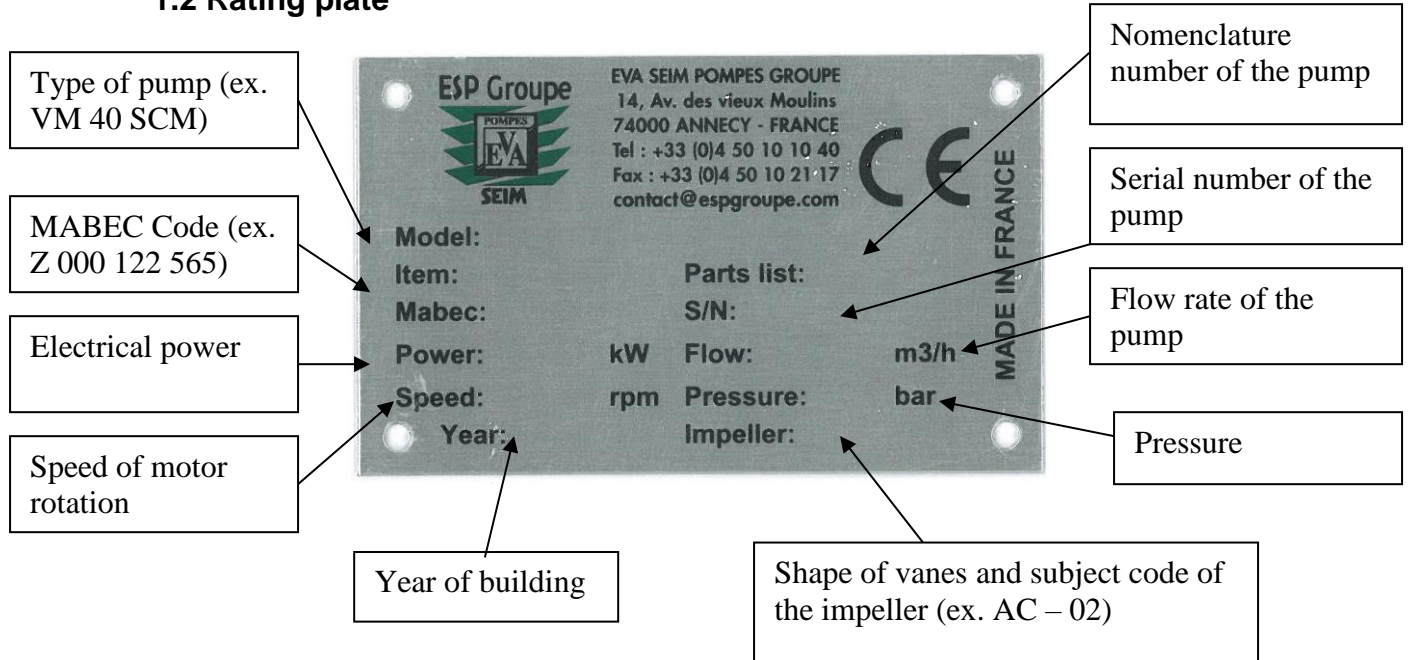

***The rating plate specifications must be given for all requests for after-sales-service and/or replacement parts.***

### 1.3 Principle of operation

Aspiration of liquid by VORTEX vane impeller

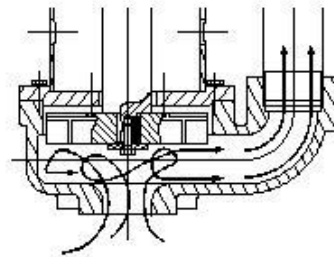

Clockwise rotation when seen from the motor side.

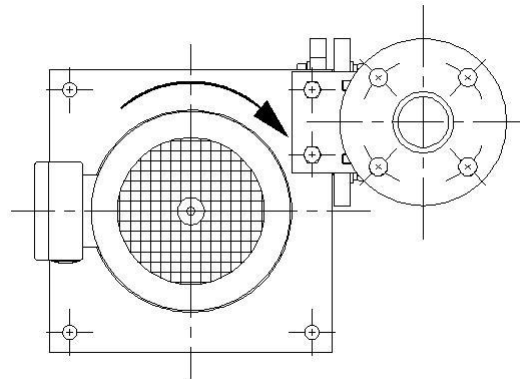

## 2. INSTRUCTIONS FOR ASSEMBLY AND INSTALLATION

### 2.1 Storage

It is preferable to store the pump covered, in its original packaging.

### 2.2 Handling

For handling and installation on the trough, sling the pump above the motor.

### 2.3 Installation

- Before installation, make sure that:
- The base plate of the trough is completely level.
- The trough has been cleaned before placement in water.

### 2.4 Connecting the line

- The diameter of the discharge line should not be less than the nominal diameter of the pump. (Especially if pumping large shavings).
- The discharge line should be perfectly maintained independently of the pump.
- The pump should never withstand the constraints of misalignment or the weight of the discharge line. These cause premature wear and tear of the pump's mechanical components.
- The suction diameter should not be reduced.



### 2.5 Electrical connection

- The stuffing boxes provided to balance tractive effort or torsional stress should be used in compliance with regulations. After loosening the screws or nuts, insert the power leads between the lower part and the presser of the terminal posts.
- The stripped ends of the wires should fill the entire length of the terminals however, they should not jut out. Make sure the leads are well in place and then retighten the screws or nuts.
- Connect the guard wire with the neutral terminal found inside the terminal box or in the case of a separate earth, connect the latter to the earth terminal.

• **Connection diagrams for three-phase motors with cage rotors**

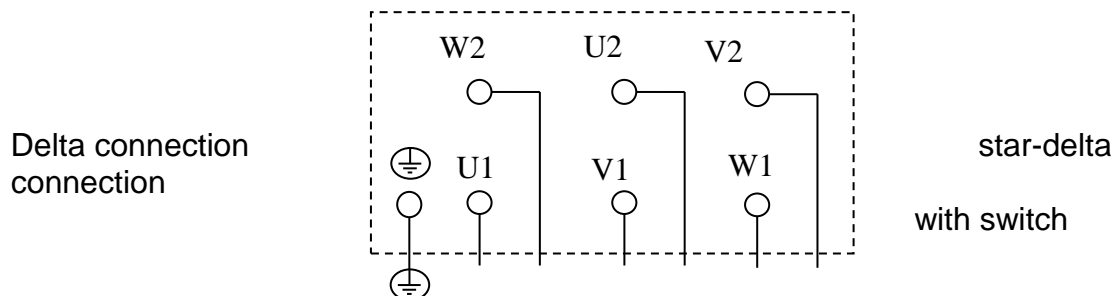

• **Connection diagrams for three-phase motors with switchable poles**

2 speed motor with separate interwinding:

In the type designation, the fewer the number of poles = the high speed is mentioned first (ex. AM 280. 4/8)

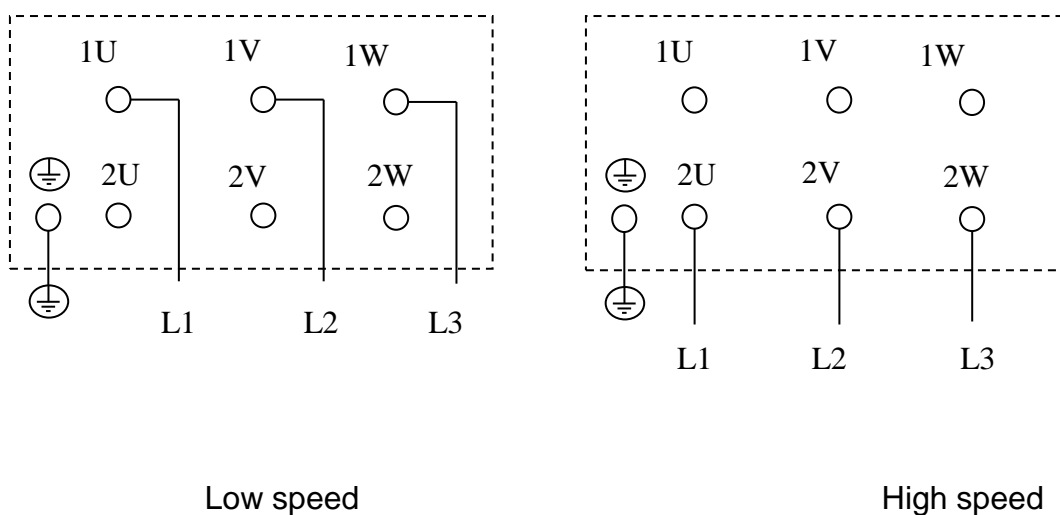

The individual connection diagrams are found in the lid of the terminal box or delivered with the motor.

### 3. INSTRUCTIONS FOR COMMISSIONING AND ADJUSTMENTS

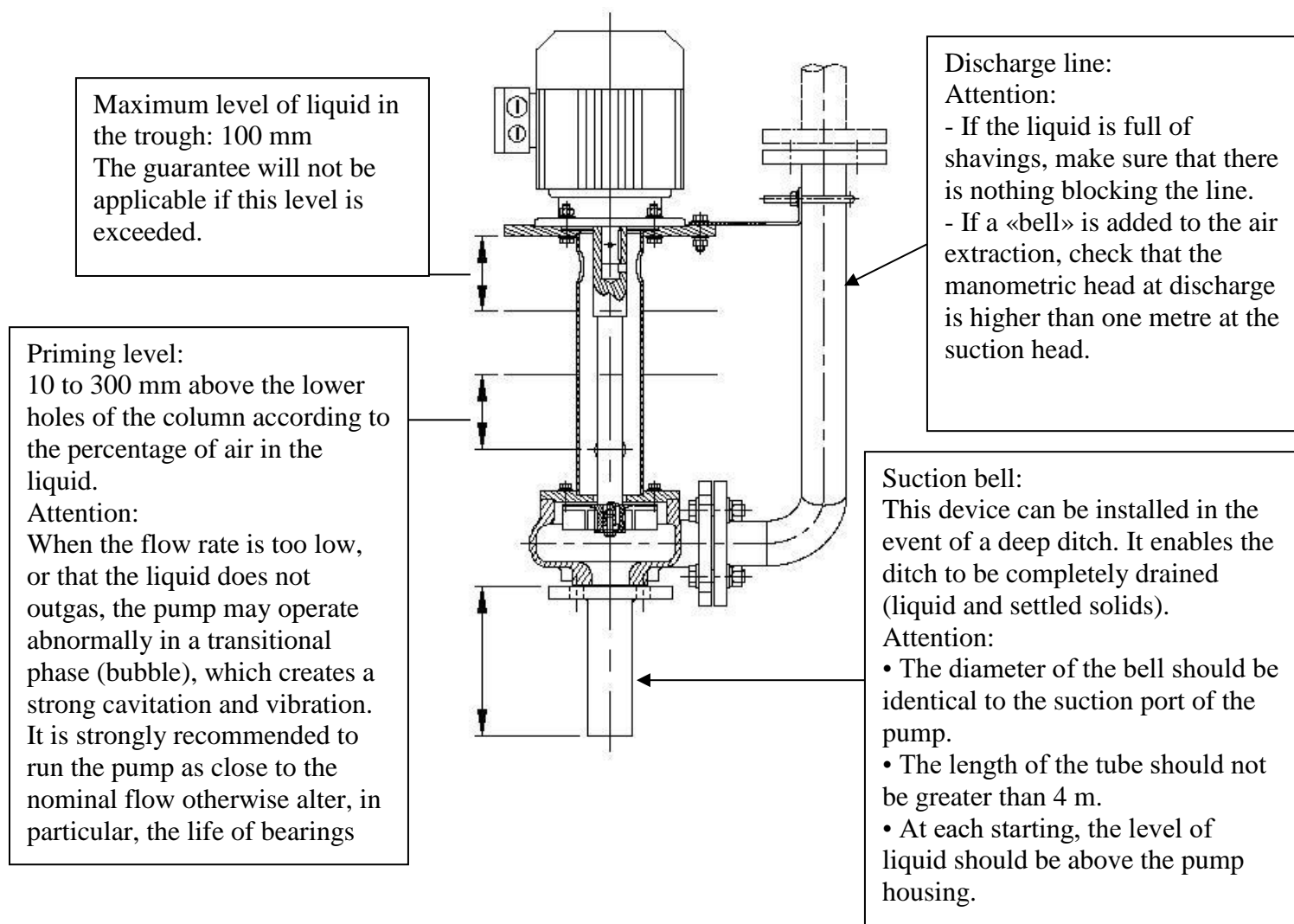

When commissioning, check the direction of the pump's rotation (clockwise when seen from the motor side).

#### **Caution:**

A VORTEX pump that turns in reverse discharges about 80% of its rated flow but consumes much more amperage (The lowest amperage corresponds to rotation in the right direction).

## 4. MAINTENANCE, SERVICING AND SAFETY

Before any intervention, make sure that the pump has been shut down:

- Electrical power cut.
- Hydraulic network disconnected.

Use personal protective equipment and the correct tools.

### 4.1 Preventive maintenance and checks.

#### - Cleaning:

Clean the motor regularly with compressed air in order to avoid any obstruction of the cooling flanges.



**Never use liquid products.**

#### - Regular checks (at least monthly):

- Inspect the fan motor cowling supports.
- Inspect the condition of the various electrical and hydraulic connections.
- Inspect abnormal noises, vibrations and any phenomena that could signal the deterioration of a pump component, the motor or a failure of the discharge line support structure.
- Inspect the greasing if applicable.

#### - Checking and replacing the impeller:

**Checking and/or replacing the impeller requires dismantling the motopump assembly. See chapter 4.3, page 10 for the dismantling procedure.**

- Half-yearly inspection for non-abrasive liquids.
- Quarterly inspection for abrasive liquids.
- Immediate inspection if the specifications of the pump diminish.

**Note:** It is recommended to delay the shutdown of the pump in case of prolonged operation without liquid (time = 3-5 minutes corresponding to the average time of recovery of overall volume and pan drippings)

## 4.2 Incidents and main causes

### CORRECTIVE MAINTENANCE AND TROUBLE-SHOOTING

The motor functions, but not the pump:	<ul style="list-style-type: none"> <li>- The half plates of the coupling are incorrectly joined.</li> </ul>
The pump functions but does not discharge:	<ul style="list-style-type: none"> <li>- The impeller is no longer on its shaft.</li> <li>- A plug is obstructing the discharge system.</li> <li>- The MTL (manometric total lift) is higher than that announced.</li> </ul>
The motor cuts out:	<ul style="list-style-type: none"> <li>- Something is blocking the turbine.</li> <li>- The MTL (manometric total lift) is lower than that announced.</li> <li>- The motor is turning in reverse.</li> <li>- The motor's rotation speed is not good.</li> <li>- The product is denser than expected.</li> </ul>
The pump vibrates abnormally:	<ul style="list-style-type: none"> <li>- The coupling is badly blocked.</li> <li>- The discharge line is constraining the pump.</li> <li>- The base plate is not attached to a level support.</li> <li>- The MTL (manometric total lift) is lower than that announced.</li> <li>- The impeller is damaged (loss of balancing).</li> </ul>
The pump makes a strange noise:	<ul style="list-style-type: none"> <li>- The fan motor is rubbing against the cowling.</li> <li>- A bearing has deteriorated.</li> <li>- The impeller rubs in the pump housing.</li> </ul>
The pump is not performing as rated:	<ul style="list-style-type: none"> <li>- The MTL (manometric total lift) is higher than initially expected.</li> <li>- The viscosity of the product is different from that announced.</li> <li>- The discharge system is clogged.</li> <li>- The motor rotation speed is not good.</li> <li>- The diameter or shape of the impeller does not comply.</li> </ul>

### 4.3 Dismantling the various pump elements

#### - Removing the pump from its trough:

- Uncouple the discharge line.
- Unscrew the 4 fastening screws of the column plate.
- Remove the motopump assembly and put it on an appropriate support.

#### - Remove the pump housing:

- Remove the 4 fastening screws of the housing.
- Remove the housing.

#### - Remove the impeller:

- Remove the support screw of the impeller and its washer.
- Remove the impeller.

#### - Uncoupling the motor - column:

- Remove the fastening screws of the motor.
- Remove the motor with the pump shaft.

#### - Uncoupling the motor – pump shaft:

- Loosen the ring block screws (see data sheet in the appendix, chapter 6.1)
- Check for, and if necessary, remove the oxidation that could have formed on the motor shaft.
- Uncouple the pump shaft from the motor shaft.

#### - Reassembly:

- Carry out the various operations in reverse order.

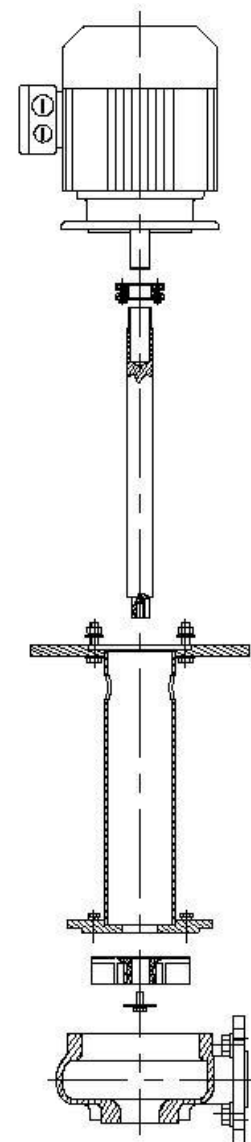

Make sure to carefully follow the assembly procedure and the tightening torque of the RING-BLOCK bushings, see chapter 6.1, page 12.

## 5. CONDITIONS OF GUARANTEES

The pumps are guaranteed for parts and labour if recognized as defective by our after-sales-service (materials returned to our workshops).

### **Excluded from the guarantee:**

- Abnormal running.
- Operation other than that provided for when ordered.
- Lack of checks and maintenance.
- Wearing parts.

**Wearing parts:** - Impeller

## 6. APPENDICES

### 6.1 Assembly sheet for the RING-BLOCK bushing

#### RING-BLOCK BUSHINGS SERIES 2200-01 ACTING BY EXTERNAL COMPRESSION

Designed for tightening a hollow shaft to a shaft that passes through it. These are used when the design of the assembly or lack of space prevents the use of traditional blocking systems between shaft and hub. Their use requires high precision machining.

#### - PRECAUTIONS FOR USE

- 1) Scrupulously follow the machining tolerances shown in the table
- 2) Roughness  $\leq 16 \mu\text{m}$
- 3) Coat the slanted surfaces with a molybdenum disulphide product in order to facilitate tightening to the indicated torque.
- 4) Always use at least 10.9 quality screws.

#### - **Assembly:**

The ring-block bushings are delivered ready-to assemble. Do not dismantle them before installation.

- 1) Make sure the two plates are parallel by separating them at a minimum of three different areas spaced  $120^\circ$  apart
- 2) Degrease and clean the 2 shafts to be coupled.
- 3) Fit the bushing in the pump shaft.

**Attention:** never tighten the screws before the pump shaft is mounted on the motor shaft.

- 4) Insert the motor shaft into the pump shaft (after reducing the shim to the necessary thickness).
- 5) Tighten the screws gradually, making sure the plates remain parallel. Tighten with a torque wrench, according to the numerical order shown on the table.  
(Several tightening turns are necessary in order to check the tightening torque of each screw).

#### - **Dismantling:**

- 1) Loosen the screws consecutively in the same order.  
Never loosen the screws completely in order to avoid binding of the plates.
- 2) Before removing the pump shaft, remove all oxidation that could have formed on the motor shaft.
- 3) Remove the ring-block bushing of the pump shaft.

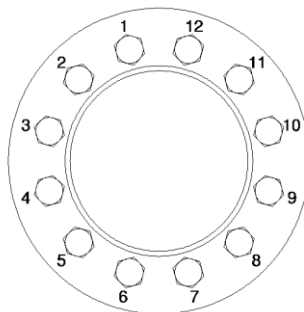
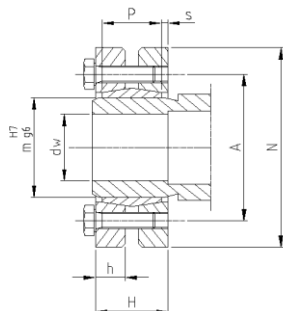

dW		tol. Jeu max	
de18	à 30	H6/j6	0.017
30	50	H6/h6	0.032
50	80	H6/g6	0.048
80	120	H7/g6	0.069
120	180	H7/g6	0.079
180	250	H7/g6	0.090
250	315	H7/g6	0.101
315	400	H7/g6	0.111
400	500	H7/g6	0.123

**DESIGNATION: RB 2200-01 x m**

Mt= transmissible torque

Nb= number of screws

Fv= maximum axial thrust

Md= tightening torque of the screws

TYPE	m mm	dw mm	Mt N.m	Fa kN	Md N.m	Nb	Vis mm	Poids Kg	N mm	P mm	h mm	H mm	A mm	s mm
2200-01 24	24	19	170	17	5	6	M 5*15	0.2	50	14	8	20	36	2
		20	210	21										
2200-01 30	30	24	300	25	5	6	M 5*18	0.3	60	16	9	22	44	2
		25	340	27										
2200-01 36	36	28	440	31	12	5	M 6*20	0.4	72	18	10	24	52	2
		30	570	38										
2200-01 44	44	34	710	41	12	7	M 6*25	0.6	80	20	11	26	61	2
		35	780	44										
2200-01 50	50	38	940	49	12	8	M 6*22	0.8	90	22	12	28	75	2
		40	1160	58										
2200-01 55	55	42	1160	55	12	8	M 6*25	1.1	100	23	13	30	75	3
		45	1520	67										
2200-01 62	62	48	1750	73	12	10	M 6*25	1.3	110	23	13	30	86	3
		50	2000	80										

## 6.2 Spare parts list

The rating plate specifications must be given for all requests for replacement parts.

- Impeller
- Housing
- Pump shaft
- Ring-block bushing
- Motor

### 6.3 Certificate of EC conformity

**DECLARATION OF CONFORMITY WITH THE  
DIRECTIVE « MACHINES »**  
(Directive 98/37/CE of 22 June 1998) and to the regulations for its transposition

#### MATERIAL SUBJECT TO AUTO CERTIFICATION

The manufacturer:



14, Avenue des Vieux Moulins  
Z.I de Vovray  
74000 ANNECY  
Tel. (+33) 04.50.10.10.40

Declares that the machine designated below:

#### MONOBLOC VERTICAL PUMP WITH VORTEX EFFECT

#### Model VM - SCM / VMT - SCM / VMS - SCM

- Conforms with the provisions of the directive « MACHINES » (Directive 89/392/EEC modified) and to the national laws that transpose it,
- Conforms with the following provisions of the European Harmonized Standards:  
CEN / TC 197 / SC1 N 36 E (pr EN 809)  
Transposed in French by law N° 91 1414 (decrees N° 92-765, 92-766 and 92-767 of 29.07.1992).

Signed at ANNECY,

The 21.10.2023

Name of the signer: C.CHENAL

Signature:

