

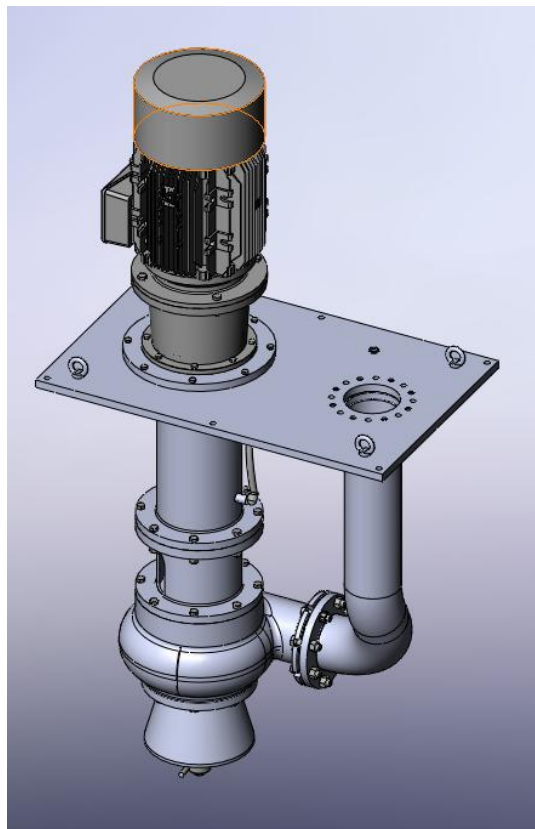

ASSEMBLY AND MAINTENANCE INSTRUCTIONS

EVA Pump

Type VM 200 SBA Cutter



CONTENTS

1. PRODUCT DESCRIPTION – PRINCIPLE OF OPERATION	3
1.1 Pump construction detail	3
1.3 Principle of operation.....	4
2. INSTRUCTIONS FOR ASSEMBLY AND INSTALLATION	4
2.1 Storage.....	5
2.2 Handling.....	5
2.3 Installation	5
2.4 Connecting the line.....	5
2.5 Electrical connection	5
3. Recommendations and adjustments to observe for:	7
4. Technical characteristics	8
4.1 Curve (1200 rpm) Impeller AD.....	8
4.2 Main characteristics and advantages	8
5. MAINTENANCE, SERVICING AND SAFETY.....	9
5.1 Preventive maintenance and checks.....	9
5.2 Incidents and main causes.....	10
5.3 Dismantling the various pump elements (pump out of lifting tank).....	11
5.4 List of components:	14
6. CONDITIONS OF GUARANTEES.....	15
7. APPENDICES.....	15
7.1 Assembly sheet for the Poly-norm	15
7.2 Certificate of EC conformity	17
MATERIAL SUBJECT TO AUTO CERTIFICATION	17

1. PRODUCT DESCRIPTION – PRINCIPLE OF OPERATION

- Vertical centrifuge pump with submerged housing and VORTEX wheel.
- Dry operation without risk of deterioration.
- Sludge lifting.

1.1 Pump construction detail

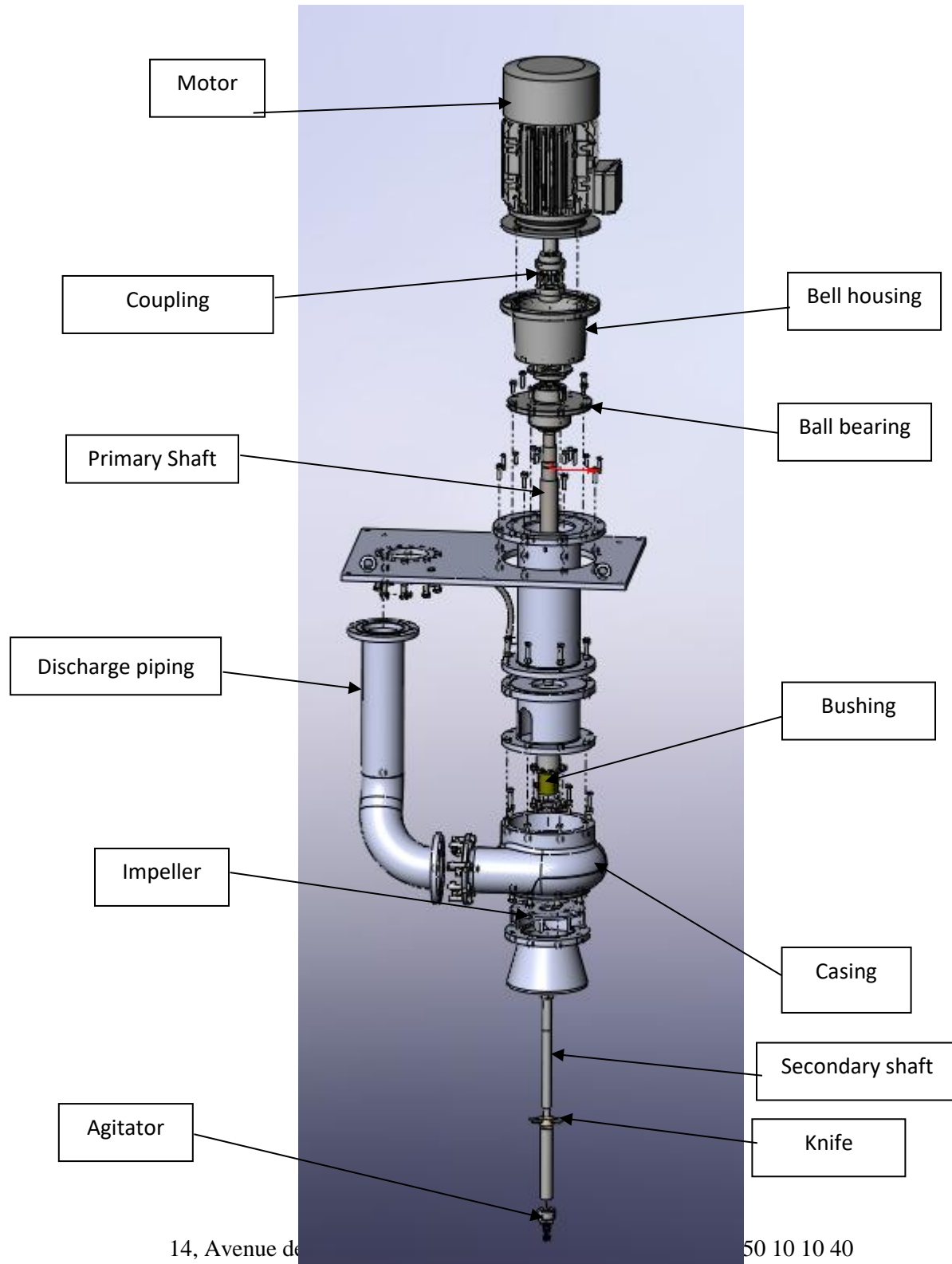

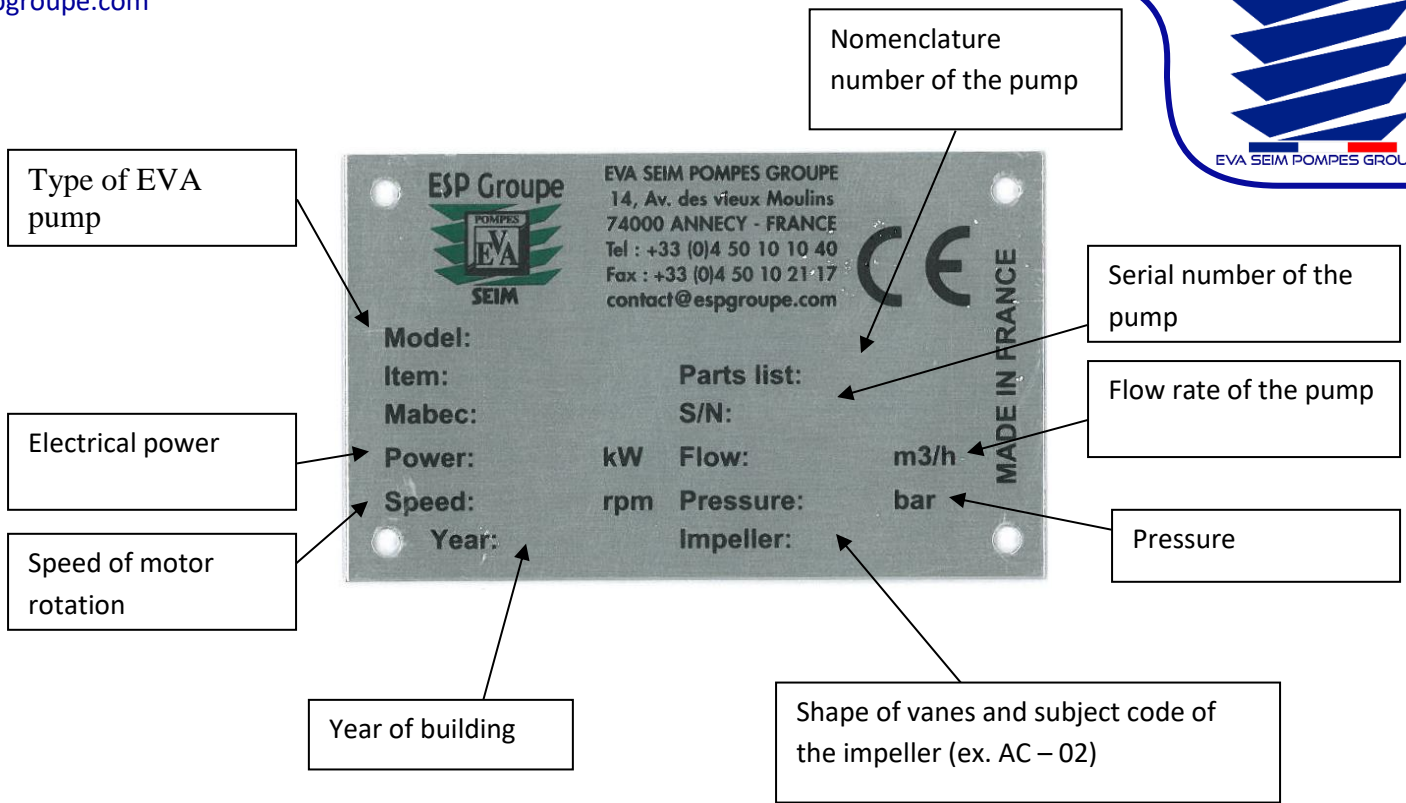

The rating plate specifications must be given for all requests for after-sales-service and/or replacement parts.

1.3 Principle of operation

Aspiration of liquid by VORTEX vane impeller

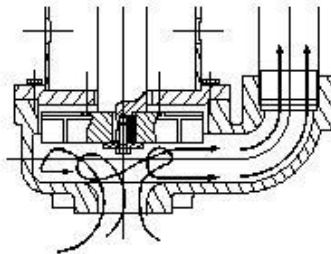

Clockwise rotation when seen from the motor side.

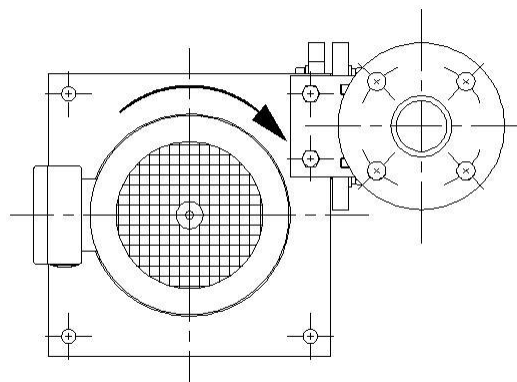

2. INSTRUCTIONS FOR ASSEMBLY AND INSTALLATION

2.1 Storage

It is preferable to store the pump covered, in its original packaging.

2.2 Handling

For handling and installation on the frame, pass a strap over the width of the plate between four rings on base plate. Net weight without motor: 510 kg

2.3 Installation

- Before installation, make sure that:
- The base plate of the trough is completely level.
- The trough has been cleaned before placement in water.

2.4 Connecting the line

- The diameter of the discharge line should not be less than the nominal diameter of the pump. (Especially if pumping large shavings).
- The discharge line should be perfectly maintained independently of the pump.
- The pump should never withstand the constraints of misalignment or the weight of the discharge line. These cause premature wear and tear of the pump's mechanical components.
- The suction diameter should not be reduced.



2.5 Electrical connection

- The stuffing boxes provided to balance tractive effort or torsional stress should be used in compliance with regulations. After loosening the screws or nuts, insert the power leads between the lower part and the presser of the terminal posts.
- The stripped ends of the wires should fill the entire length of the terminals however, they should not jut out. Make sure the leads are well in place and then retighten the screws or nuts.
- Connect the guard wire with the neutral terminal found inside the terminal box or in the case of a separate earth, connect the latter to the earth terminal.

• Connection diagrams for three-phase motors with cage rotors

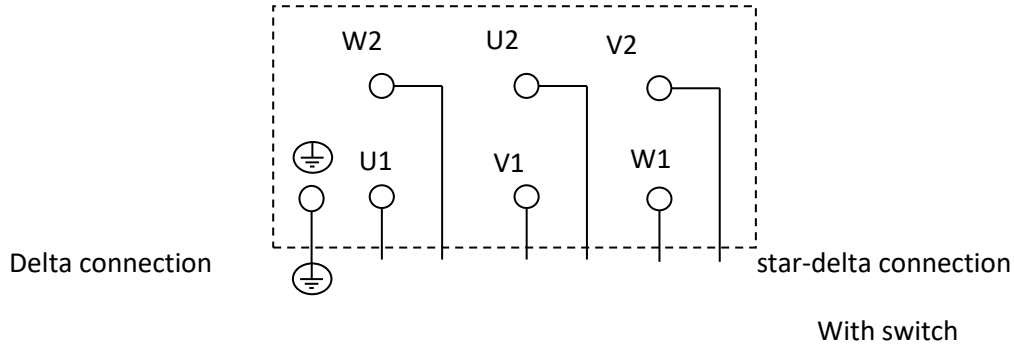

• Connection diagrams for three-phase motors with switchable poles

2 speed motor with separate inter windings:

In the type designation, the fewer the number of poles = the high speed is mentioned first (ex. AM 280. 4/8)

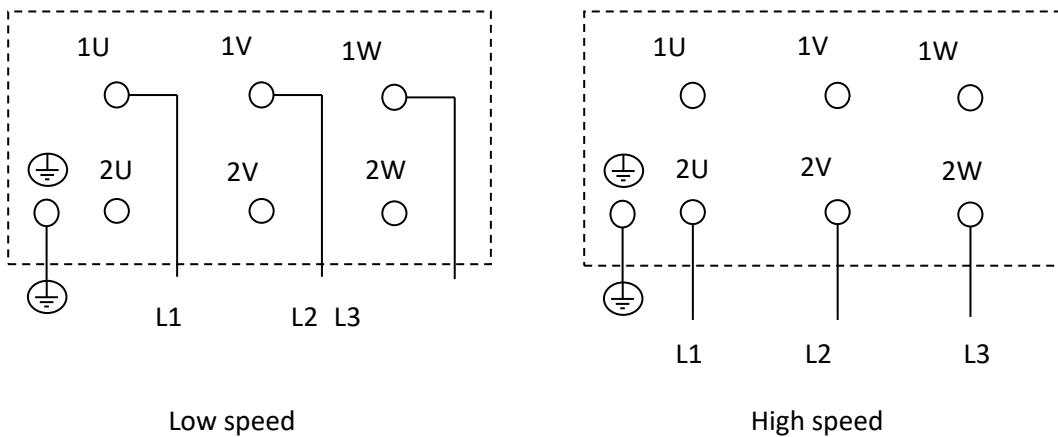

The individual connection diagrams are found in the lid of the terminal box or delivered with the motor.

3. Recommendations and adjustments to observe for:

- Manufacturing of tank
- Position of the cutter pump EVA inside the tank
- working conditions

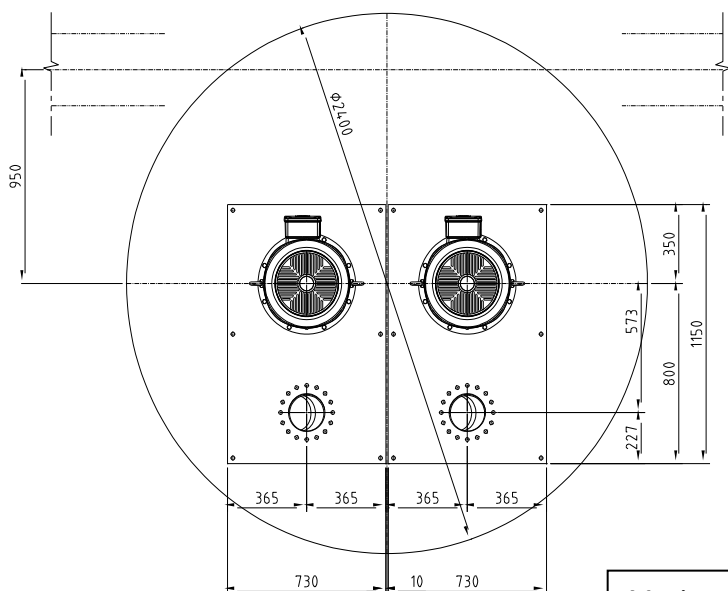

Discharge line:

Pay Attention:

- Checking if there is nothing blocking the line because of risk of overflow
- The pipe of the pump have to be connected with elastic sleeve to the pipe of the network to avoid risk of vibration

Motor

Speed limited up to 1750 tr/mn
Pay attention to the direction indicated with arrow

Maximum level liquid in the trough= 100mm
The guarantee will not be applicable if this level is exceeded

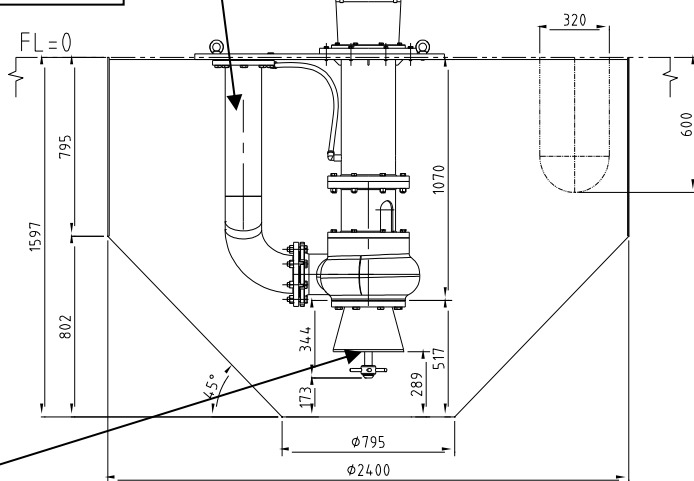
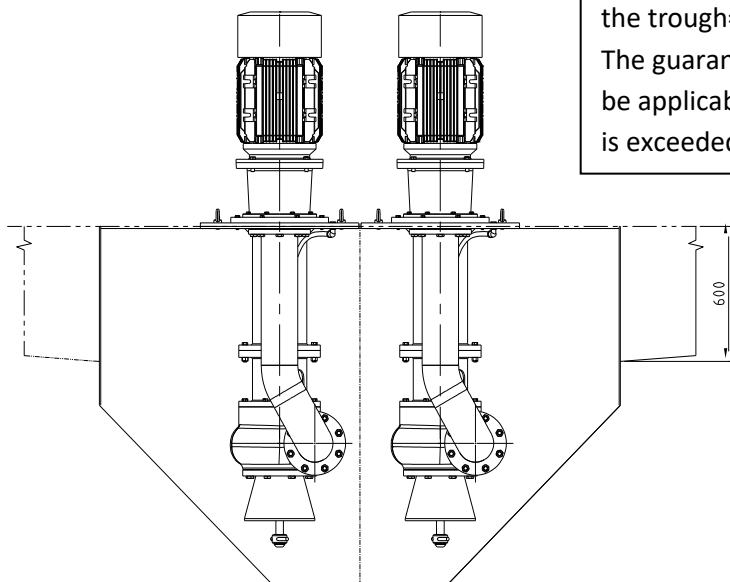

Suction:

This device can be installed in the event of a deep ditch. It enables the ditch to be completely drained (liquid and settled solids).

Attention:

- The diameter of the inline pipe should be identical to the suction port of the pump.
- The length of the inline pipe should not be greater than 1 m.
- At each starting, the level of liquid should be above the pump housing.

The Guarantee of the EVA pump does not apply if these recommendations are not respected

4. Technical characteristics

4.1 Curve (1200 rpm) Impeller AD

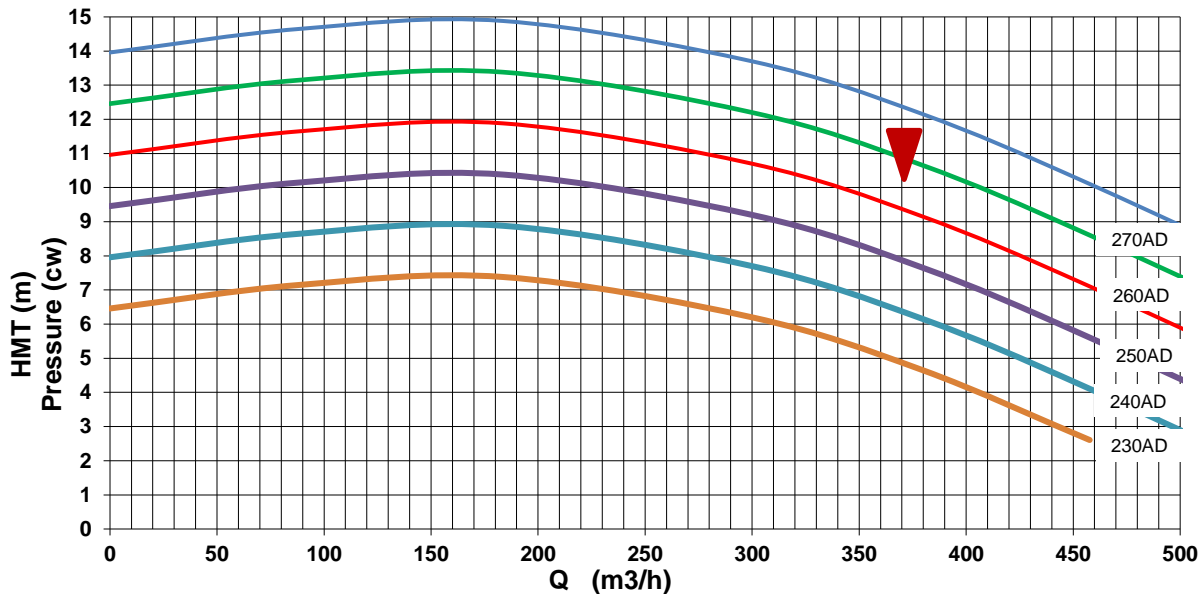

4.2 Main characteristics and advantages

- Vortex Impeller
- Protection against running dry during - starting working (limited at 15 min maxi)
- Cutter with special design patented by EVA for a better cutting
- Used for aluminium chips – steel chips with very low alloy and very thin- cast iron GG25 very thin
- Load aluminium chips : up 15 g/l
- Load steel and cast iron : up 5 g/l
- Length of aluminium chips up 120 mm
- Length of aluminium chips after cutting : average 50 mm
- Length of steel chips very low alloy and thin : up : 50 mm
- Length of cast iron chips very thin and GG 25 : up 50 mm
- Fluid : Emulsion or oil up 32 Cst
- Air : up 10 % with special impeller patented EVA (For % > on request)
- Motor 22kW 6P (H200) 440V 60Hz IE3
- Outline : Din or ANSI Size : DN 50 and 65 2" – 2"1/2
- Casing : cast Iron GGG50
- Impeller: cast Iron GGG50 or carbon steel (on request)
- Cutter: Hard material with hard treatment

5. MAINTENANCE, SERVICING AND SAFETY

Before any intervention, make sure that the pump has been shut down:

- Electrical power cut.
- Hydraulic network disconnected.

Use personal protective equipment and the correct tools.

5.1 Preventive maintenance and checks.

- Cleaning:

Clean the motor regularly with compressed air in order to avoid any obstruction of the cooling flanges.



Never use liquid products.

- Regular checks (at least monthly):

- Inspect the fan motor cowling supports.
- Inspect the condition of the various electrical and hydraulic connections.
- Inspect abnormal noises, vibrations and any phenomena that could signal the deterioration of a pump component, the motor or a failure of the discharge line support structure.
- Inspect the greasing if applicable.

- Checking and replacing the impeller:

Checking and/or replacing the impeller requires dismantling the moto pump assembly. See chapter 4.3, page 10 for the dismantling procedure.

- Half-yearly inspection for non-abrasive liquids.
- Quarterly inspection for abrasive liquids.
- Immediate inspection if the specifications of the pump diminish.

Note: It is recommended to delay the shutdown of the pump in case of prolonged operation without liquid (time = 3-5 minutes corresponding to the average time of recovery of overall volume and pan drippings)

5.2 Incidents and main causes

CORRECTIVE MAINTENANCE AND TROUBLE-SHOOTING

The motor functions, but not the pump:	- The half plates of the coupling are incorrectly joined.
The pump functions but does not discharge:	- The impeller is no longer on its shaft. - A plug is obstructing the discharge system. - The MTL (manometric total lift) is higher than that announced.
The motor cuts out:	- Something is blocking the turbine. - The MTL (manometric total lift) is lower than that announced. - The motor is turning in reverse. - The motor's rotation speed is not good. - The product is denser than expected.
The pump vibrates abnormally:	- The coupling is badly blocked. - The discharge line is constraining the pump. - The base plate is not attached to a level support. - The MTL (manometric total lift) is lower than that announced. - The impeller is damaged (loss of balancing). - Cutter, agitator or secondary shaft is damaged → to be check and change if necessary
The pump makes a strange noise:	- The fan motor is rubbing against the cowling. - A bearing has deteriorated. - The impeller is rubbing in the pump casing. - The cut is rubbing against the cutting flange. - Lower bushing is wearing to be check and remove if necessary
The pump is not performing as rated:	- The MTL (manometric total lift) is higher than initially expected. - The viscosity of the product is different from that announced. - The discharge system is clogged. - The motor rotation speed is not good. - The diameter or shape of the impeller does not comply.
The pump is not cutting chips:	- The knife must be grind or change.

5.3 Dismantling the various pump elements (pump out of lifting tank)

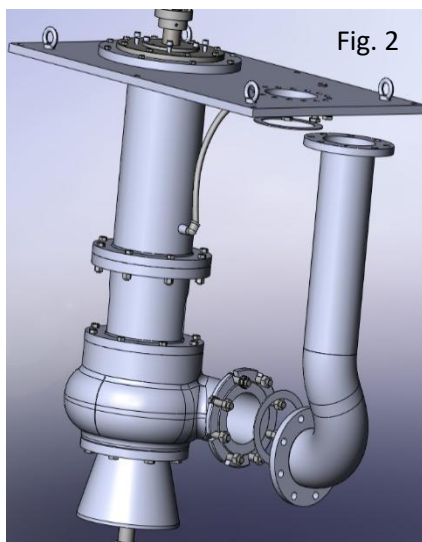
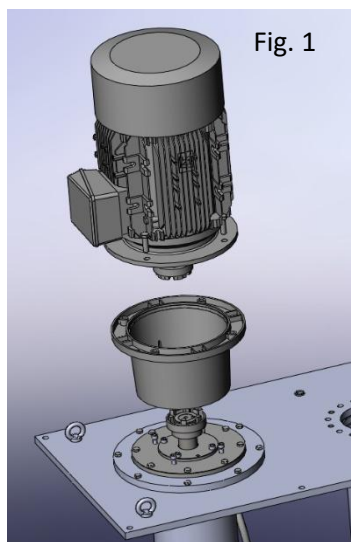

1- Removing the pump from its trough:

1. Unscrew the 4 screws from motor (fig 1)
2. Unscrew the 4 screws from bell housing (fig 1)
3. Remove the moto pump assembly and put it on an appropriate support (fig 2)
4. Disconnect the discharge line. (fig 2)

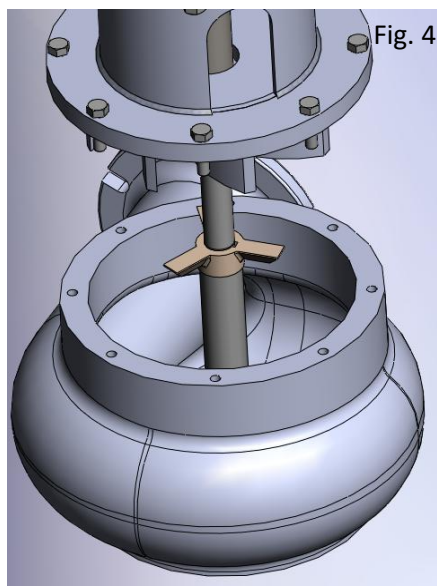
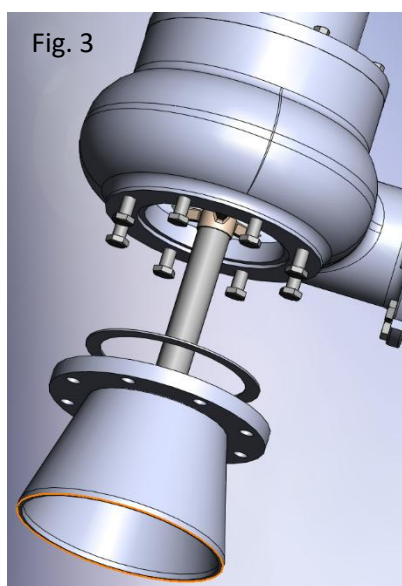

2- Remove the tulip and the casing

1. Unscrew the 8 screws from the suction piping (fig 3)
 2. Unscrew the 8 screws from the casing (fig 4)
- Caution:
Remove casing pump paying attention to the secondary shaft, knife and agitator assembly

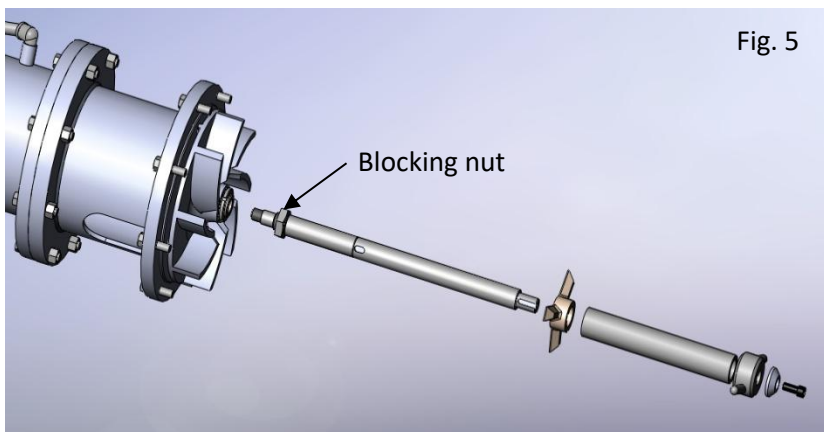

3- Remove the secondary shaft

1. Unscrew the blocking nut
2. Unscrew the set of secondary shaft
3. Remove the blocking screw of the agitator
4. Remove the clamping cone and the agitator

5. Remove the spacer and the knife

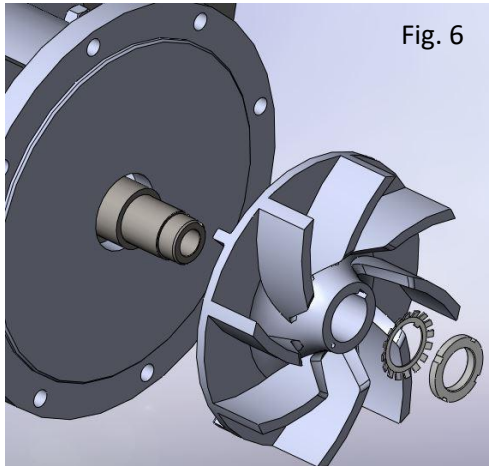

4- Remove the impeller:

1. Remove the notched washer and locknut of the impeller
2. Remove the impeller

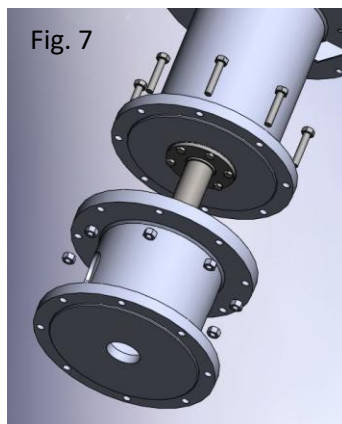

5- Remove the spacer

1. Unscrew the screws of the spacer and remove the spacer

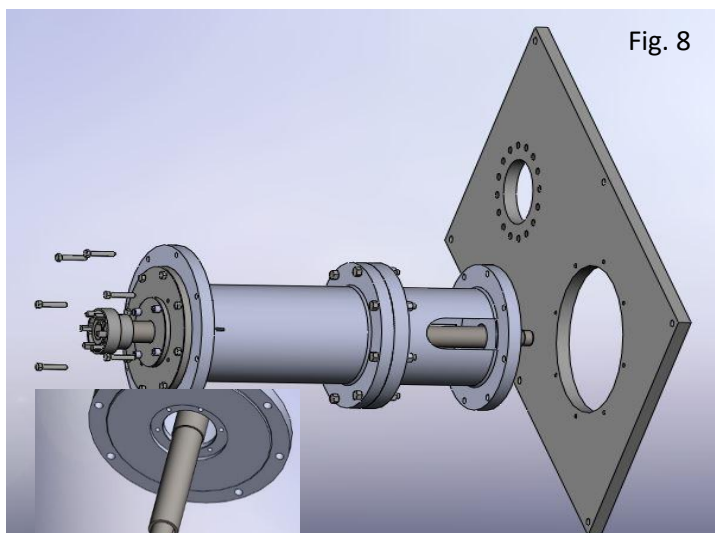

6- Remove the base plate

1. Unscrew the screws of the base plate

7- Remove the bearing support

1. unscrew the bearing cap
2. Remove the bearing support

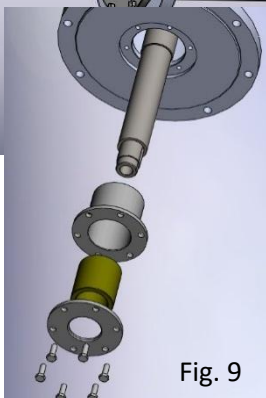

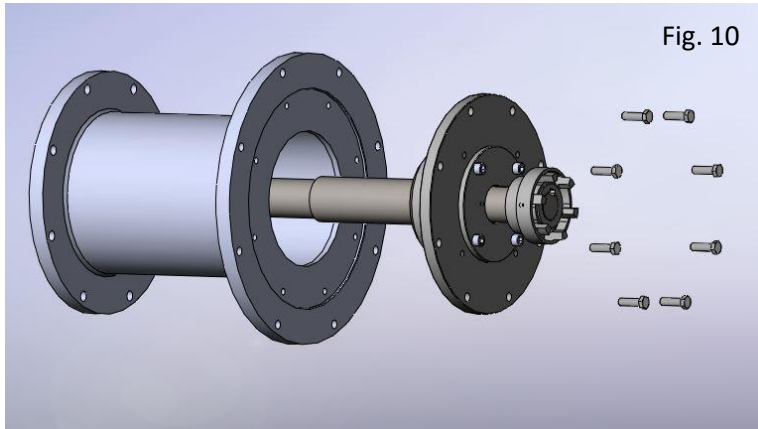

Fig. 10

8- Remove the shaft

1. Unscrew the bearing box + shaft fixing screw from the column
2. Remove the set of shaft and bearing box

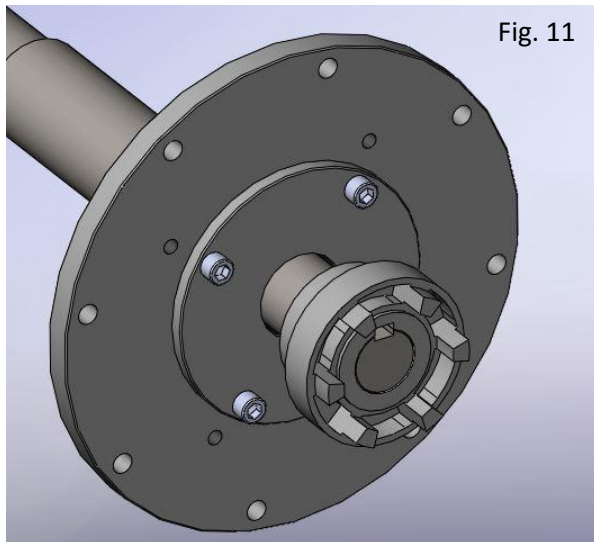

Fig. 11

9- Uncoupling the pump shaft (polynorm version):

3. Loosen the coupling block screws: see data sheet in the appendix, chapter 7.1
4. Check for, and if necessary, remove the oxidation that could have formed on the motor shaft.

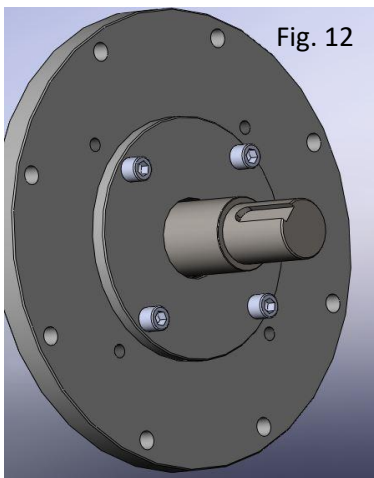

Fig. 12

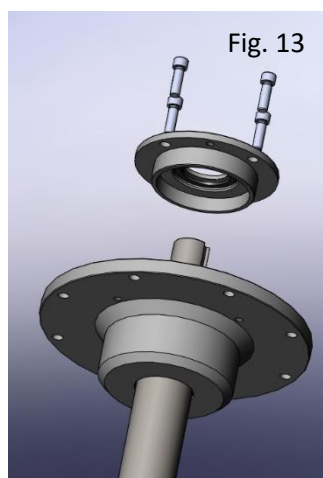

Fig. 13

10- Remove the double row ball bearing

1. unscrew the 4 screw of the bearing box cover (fig 12)
2. Remove the shaft with ball bearing (fig 13)

11- Separation shaft and bearing

- Reassembly:

Carry out the various operations in reverse order.

5.4 List of components:

- Item 09 → Column
- Item 44 → base plate
- Item 47 → Knife
- Item 01 → Pump casing
- Item 02 → Impeller
- Item 15 → bell housing
- Item 14 → Motor
- Item 49 → spacer
- Item 08 → Shaft
- Item 12 → Coupling (poly-norm)
- Item 39 → secondary shaft
- Item 30 → sleeve bearing
- Item 24 → bearing Support
- Item 38 → Nut for blocking secondary shaft
- Item 22 → Discharge pipe
- Item 40 → Agitator
- Item 26 → suction piping

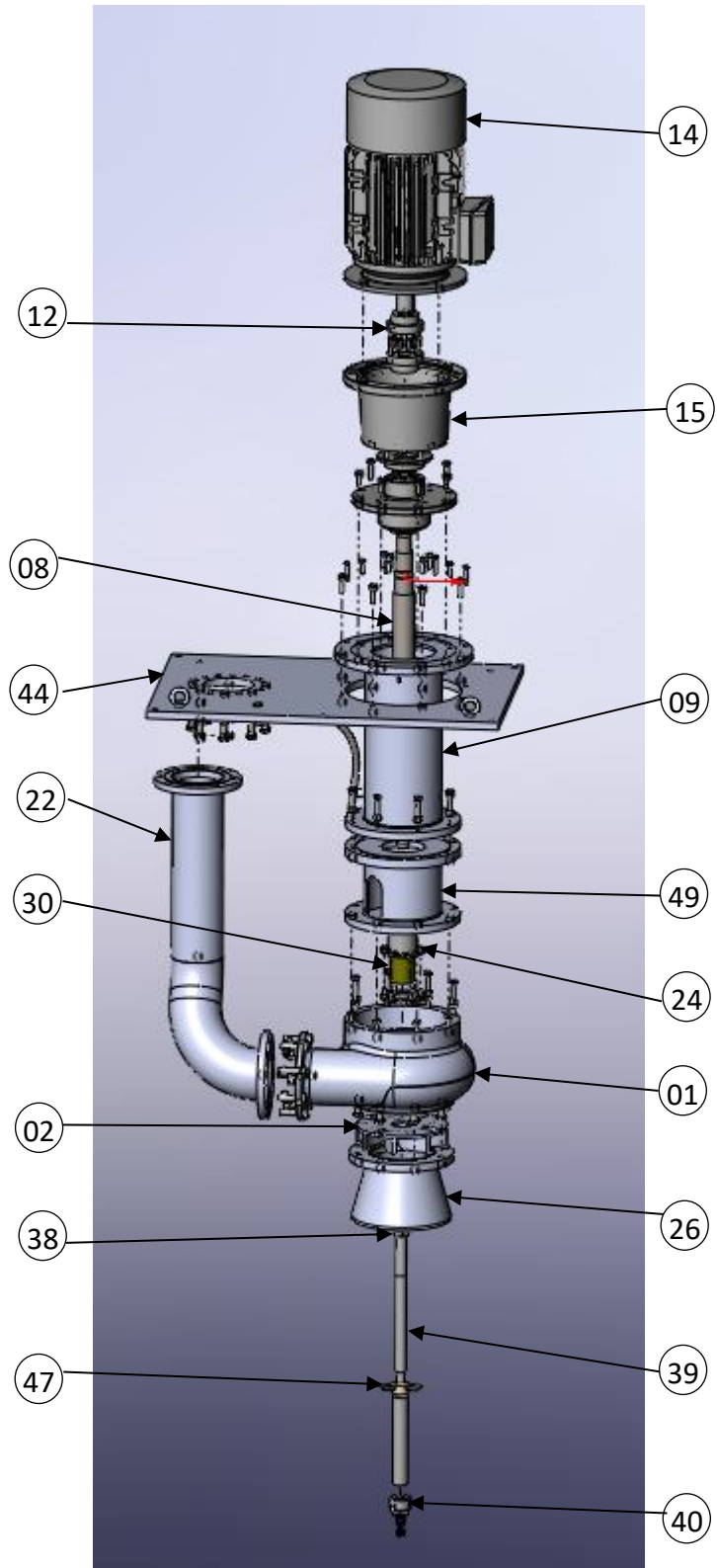

6. CONDITIONS OF GUARANTEES

The pumps are guaranteed for parts and labour if recognized as defective by our after-sales-service (materials returned to our workshops).

Excluded from the guarantee:

- Abnormal running.
- Operation other than that provided for when ordered.
- Lack of checks and maintenance.
- Wearing parts.

Wearing parts: - Impeller / knife

7. APPENDICES

7.1 Assembly sheet for the Poly-norm

- PRECAUTIONS FOR USE

1) before start-up for the coupling, please inspect the tightening of the setscrews in the hubs, the alignment and the distance dimension s and adjust, if necessary, and also inspect all screw connection for the tightening torques specified, dependent on the type of coupling

- **Assembly:** The coupling is generally supplied in individual parts. Before assembly the coupling has to be inspected for completeness.

Components of POLY-NORM[®], type AR

Component	Quantity	Description	Material	Balancing condition
1	2	Hub	EN-GJL-250	According to customer specification
2	1	Elastomer ring/DZ individual elastomers	NBR (Perbunan) from size 200 T-PUR	
9	2	Setscrews DIN EN ISO 4029	Steel	

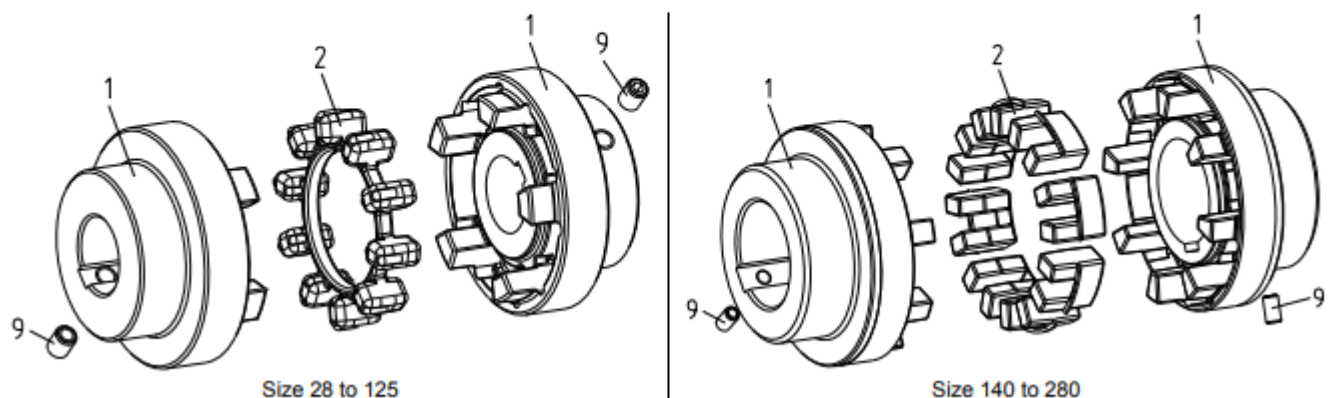

Illustration 9: POLY-NORM[®], type AR

Assembly of type AR

- Mount the hubs on the shaft of driving and driven side (see illustration 17).
- Insert the elastomer ring or DZ individual elastomers, respectively, into the cam section of the drive- or driven-sided hub (see illustration 18.1 and 18.2).

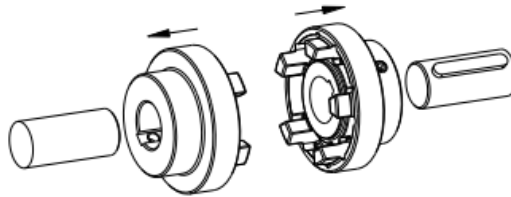

Illustration 17: Assembly of hub

Insert the DZ individual elastomers with the web into the cam section of the hub first (see illustration 18.2).

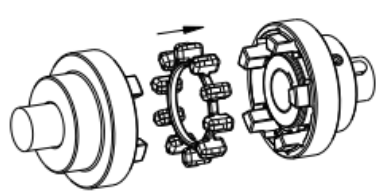

Illustration 18.1: Assembly of elastomer ring

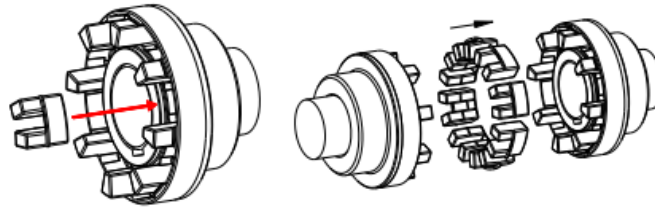

Illustration 18.2: Assembly of DZ individual elastomers

- Shift the power packs in axial direction until the distance dimension s is achieved (see illustration 19).
- If the power packs are already firmly assembled, shifting the hubs axially on the shafts allows for adjusting the dimension s (see illustration 19).
- Fasten the hubs by tightening the setscrews DIN EN ISO 4029 with a cup point (tightening torques see table 2).

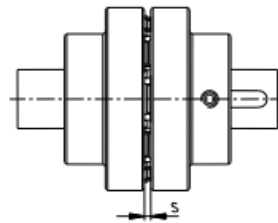

Illustration 19: Assembly of coupling

- Dismantling:

Table 1: Dimensions and torques – type AR

POLY-NORM® AR Cast iron (EN-GJL-250)													
Size	Elastomer ring ¹⁾ Torque [Nm]		Finish bore ²⁾ d _{max}	Dimensions [mm]									Weight ⁴⁾ [kg]
	T _{RN}	T _{Rmax}		General						Thread for setscrews ³⁾			
			L _{AR}	l ₁	s	D _H	D	d _H	N	G	t		
28	40	80	30	59	28	3	69	46	36.5	12.0	M5	7	0.77
32	60	120	35	68	32	4	78	53	41.5	14.0	M8	7	1.14
38	90	180	40	80	38	4	87	62	50.0	19.5	M8	10	1.59
42	150	300	45	88	42	4	96	69	55.5	20.0	M8	10	2.17
48	220	440	50	101	48	5	106	78	64	24.0	M8	15	3.03
55	300	600	60	115	55	5	118	90	73	29.0	M8	14	4.27
60	410	820	65	125	60	5	129	97	81	33.0	M8	15	5.32
65	550	1100	70	135	65	5	140	105	86	36.0	M10	20	6.86
75	850	1700	80	155	75	5	158	123	100	42.5	M10	20	10.25
85	1350	2700	90	175	85	5	182	139	116	48.5	M10	25	15.05
90	2000	4000	95	185	90	5	200	148	128	49.0	M12	25	19.50
100	2900	5800	110	206	100	6	224	165	143	55.0	M12	25	26.98
110	3900	7800	50-120	226	110	6	250	185	158	60.0	M16	30	38.12
125	5500	11000	55-140	256	125	6	280	210	178	70.0	M16	35	54.21
140	7200	14400	65-155	286	140	6	315	235	216	76.5	M20	35	77.28
160	10000	20000	75-175	326	160	6	350	265	246	94.5	M20	45	106.24
180	13400	26800	75-200	366	180	6	400	300	290	111.5	M20	50	155.20
200	19000	38000	200	408	200	8	450	335	-	126	M24	50	218.50
220	30000	60000	220	448	220	8	500	370	-	140	M24	50	296.10
240	43000	86000	240	488	240	8	550	405	-	154	M24	50	390.00
260	55000	110000	260	530	260	10	650	440	-	158	M24	60	575.00
280	67000	134000	280	570	280	10	700	475	-	172	M24	60	716.00

1) Material Perbunan (NBR) 78 Shore A with size 28 to 180; material T-PUR 84 Shore A with size 200 to 280; with size 140 to 280 use of DZ individual elastomers
 2) Bores H7 with keyway to DIN 6885 sheet 1 [JS9] and thread for setscrew on the keyway
 3) Tightening torques of setscrews see table 2
 4) Weights apply for max. bore diameters with feather keyway according to DIN 6885 sheet 1

- 1) Before removing the pump shaft, remove all oxidation that could have formed on the motor shaft.
- 2) Remove the Poly-norm of the pump shaft.

7.2 Certificate of EC conformity

**DECLARATION OF CONFORMITY WITH THE
DIRECTIVE « MACHINES »**
(Directive 2006/42/CE) and to the regulations for its transposition

MATERIAL SUBJECT TO AUTO CERTIFICATION

The manufacturer:



14, Avenue des vieux moulins
Z.I de Vovray
74000 ANNECY
Tel. (+33) 04.50.10.10.40

Declares that the machine designated below:

MONOBLOC VERTICAL PUMP WITH VORTEX EFFECT

Model EVA VM SBA CUTTER

- Conforms with the provisions of the directive « MACHINES » (Directive 2006/42/CE) and to the national laws that transpose it,
- Conforms with the following provisions of the European Harmonized Standards:
CEN / TC 197 / SC1 N 36 E (pr EN 809)
Transposed in French by law N° 91 1414 (decrees N° 92-765, 92-766 and 92-767 of 29.07.1992).

Signed at ANNECY,

The 03.01.2023

Name of the signer: S.CHENAL

Signature:

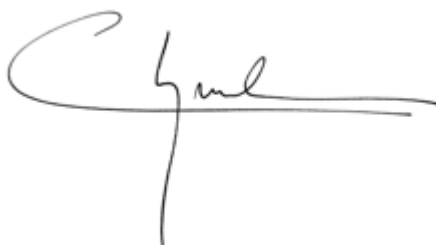

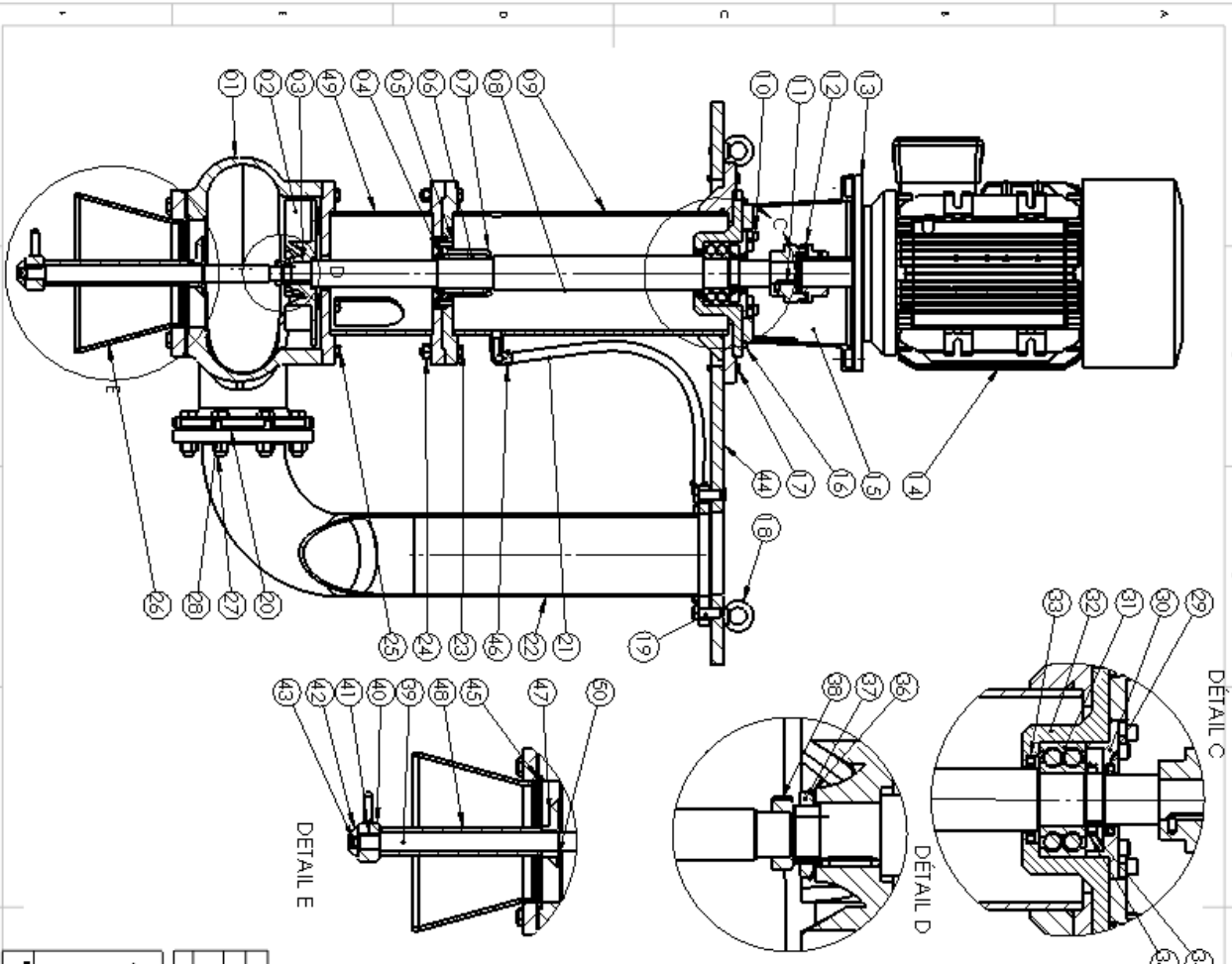

Item	Qty	DESIGNATION	Reference	Code	Material
49	1	Spacer	EN1-15584-04		S235JR
48	1	Spacer	EN-15641-08		Z160CDVA12
47	1	Knife	COLU-15588-26		KUNGERSEAL
46	2	Elbow 1/2" BSP M/F	COU04015-AFV08-201		S235JR
45	1	Flat gasket	JTP1200-PM10-27		S235JR
44	1	Base plate	PLD200-15580-04		
43	1	Screw	CHC-M12x25		
42	1	Clamping cone	BLD0200-15594-08		HARDOX
41	1	Key	8x7 / 35		
40	1	Agitator	AG1200-15629-06		XC48
38	1	Flat Nut	HM130 x 2		
37	1	Locknut	KMB08-06		
36	1	Lockwasher	KMB08-06		
35	1	Lockwasher	MBL2		
34	1	Locknut	KWL2		
32	1	Bearing box	JTPA200-7224.97-16		
31	1	Double row ball bearing	BAR200-15588-06		C45
30	1	Bearing box cover	ROUL-5312Z/RS1-04		S235JR
29	1	Lipseal	COU0200-15582-04		FPW
28	8	Nut	HM/20		
27	1	Discharge pump piping bolt	HM 20x80		
26	1	Suction piping	TA200-15597-04		
25	8	Casing fixing screw	HM14.50 + WM4		
24	8	Nut	HM14		
23	8	Spacer fixing screw	HM16x75		
22	1	discharge pipe	PCT15587 TR		
21	1	Flexible 1/2"	TR150-15596-04		
20	2	Flat gasket	NO150 NP16		
19	6	Discharge pump piping screw	HM20x45		
18	1	Lift ring M16	ANNEAU-M16-246-04		
17	8	Column fixing screw	HM12x55 + WM2		
16	8	Bearing box fixing screw	HM12x40 + WM2		
15	1	Bell housing	PK 400-05-05		ALUMINIUM
14	1	Motor	SES 200LU22KXV6P		
13	4	Motor fixing screw	HM16x45 + WM6		
12	1	Coupling	POLYMDRM AR 95		
11	1	Key	14 x 9 / 40		
10	4	Bell housing fixing screw	CHC-M12x40 + WM2		
09	1	Column	COL200-15579-04		
08	1	Column	COL200-15579-04		
07	1	Bearing support	AR8200-15581-07		
06	1	Sleeve bearing	PA150P-15585-04		
05	6	Bearing fixing screws	CO-25 Ø60-80-90		
04	1	Bearing cap	HM10.30 + WM10		
03	1	Key	12 x 8 / 25		
02	1	Impeller	Ø250x4D		
01	1	Casing	IMU25.04D-12194-31		

ESP GROUPE
 S.A. - Rue Vercors
 31100 - CAZENAC
 TEL : 05 62 18 06 50 ou 05 62 18 06 51
 FAX : 05 62 18 06 52 ou 05 62 18 06 53
 e-mail : contact@espgroupe.com

ESP GROUPE
 S.A. - Rue Vercors
 31100 - CAZENAC
 TEL : 05 62 18 06 50 ou 05 62 18 06 51
 FAX : 05 62 18 06 52 ou 05 62 18 06 53
 e-mail : contact@espgroupe.com

ESP GROUPE
 S.A. - Rue Vercors
 31100 - CAZENAC
 TEL : 05 62 18 06 50 ou 05 62 18 06 51
 FAX : 05 62 18 06 52 ou 05 62 18 06 53
 e-mail : contact@espgroupe.com

ESP GROUPE
 S.A. - Rue Vercors
 31100 - CAZENAC
 TEL : 05 62 18 06 50 ou 05 62 18 06 51
 FAX : 05 62 18 06 52 ou 05 62 18 06 53
 e-mail : contact@espgroupe.com

Designation
SECTIONAL DRAWING

N°: PH15639

